

MOUNTING AND OPERATING INSTRUCTIONS



EB 3136 EN

Translation of original instructions



Type 2488 N/5857 Pressure-independent Control Valve (PICV)

Note on these mounting and operating instructions

These mounting and operating instructions assist you in mounting and operating the device safely. The instructions are binding for handling SAMSON devices.

- For the safe and proper use of these instructions, read them carefully and keep them for later reference.
- If you have any questions about these instructions, contact SAMSON's After-sales Service Department (aftersaleservice@samson.de).



The mounting and operating instructions for the devices are included in the scope of delivery. The latest documentation is available on our website at www.samson.de > **Service & Support** > **Downloads** > **Documentation**.

Definition of signal words

DANGER

Hazardous situations which, if not avoided, will result in death or serious injury

WARNING

Hazardous situations which, if not avoided, could result in death or serious injury

NOTICE

Property damage message or malfunction

Note

Additional information

Tip

Recommended action

1	Safety instructions and measures	4
1.1	Notes on possible severe personal injury	6
1.2	Notes on possible personal injury	7
1.3	Notes on possible property damage	7
2	Markings on the device	8
2.1	Nameplate for Type 2488 N Valve	8
3	Design and principle of operation	9
3.1	Technical data	10
4	Measures for preparation	14
4.1	Unpacking	14
4.2	Transporting and lifting	14
4.3	Storage	15
4.4	Preparation for installation	16
5	Mounting and start-up	16
5.1	Mounting position	16
5.2	Additional fittings	17
5.3	Mounting the actuator	17
5.4	Electrical connection	18
5.5	Start-up	19
6	Operation	20
6.1	Adjusting the set points	20
6.1.1	Flow rate	20
7	Servicing	21
7.1	Preparation for return shipment	22
7.2	Ordering spare parts and operating supplies	23
8	Malfunctions	23
8.1	Decommissioning	24
8.2	Disposal	24
9	Appendix	24
9.1	After-sales service	24
9.2	Certificates	25

1 Safety instructions and measures

Intended use

The Type 2488 N/5857 Pressure-independent Control Valve (PICV) is intended for flow control of liquids up to 110 °C. The Type 2488 N/5857 is mainly used in district heating supply networks. The regulator and actuator are designed to operate under exactly defined conditions (e.g. operating pressure, process medium, temperature). Therefore, operators must ensure that the regulator and actuator are only used in operating conditions that meet the specifications used for sizing the devices at the ordering stage. In case operators intend to use the devices in other applications or conditions than specified, contact SAMSON.

SAMSON does not assume any liability for damage resulting from the failure to use the device for its intended purpose or for damage caused by external forces or any other external factors.

➔ Refer to the technical data and nameplate for limits and fields of application as well as possible uses.

Reasonably foreseeable misuse

The regulator is not suitable for the following applications:

- Use outside the limits defined during sizing and by the technical data

Furthermore, the following activities do not comply with the intended use:

- Use of non-original spare parts
- Performing service and repair work not described in these instructions

Qualifications of operating personnel

The regulator must be mounted, started up, serviced and repaired by fully trained and qualified personnel only; the accepted industry codes and practices are to be observed. According to these mounting and operating instructions, trained personnel refers to individuals who are able to judge the work they are assigned to and recognize possible hazards due to their specialized training, their knowledge and experience as well as their knowledge of the applicable standards.

Operators are additionally responsible for ensuring that the limits for the product defined in the technical data are observed. This also applies to the start-up and shutdown procedures. Start-up and shutdown procedures fall within the scope of the operator's duties and, as such, are not part of these mounting and operating instructions. SAMSON is unable to make any statements about these procedures since the operative details (e.g. differential pressures and temperatures) vary in each individual case and are only known to the operator.

Personal protective equipment

We recommend wearing the following protective equipment depending on the process medium:

- Protective clothing, gloves and eyewear in applications with hot, cold and/or corrosive media
 - Wear hearing protection when working near the valve.
- Check with the plant operator for details on further protective equipment.

Revisions and other modifications

Revisions, conversions or other modifications of the product are not authorized by SAMSON. They are performed at the user's own risk and may lead to safety hazards, for example. Furthermore, the product may no longer meet the requirements for its intended use.

Warning against residual hazards

To avoid personal injury or property damage, plant operators and operating personnel must prevent hazards that could be caused in the regulator by the process medium, the operating pressure or by moving parts by taking appropriate precautions. They must observe all hazard statements, warning and caution notes in these mounting and operating instructions, especially for installation, start-up and service work.

Responsibilities of the operator

The operator is responsible for proper operation and compliance with the safety regulations. Operators are obliged to provide these mounting and operating instructions as well as the referenced documents to the operating personnel and to instruct them in proper operation. Furthermore, the operator must ensure that operating personnel or third persons are not exposed to any danger.

Responsibilities of operating personnel

Operating personnel must read and understand these mounting and operating instructions as well as the referenced documents and observe the specified hazard statements, warnings and caution notes. Furthermore, the operating personnel must be familiar with the applicable health, safety and accident prevention regulations and comply with them.

Referenced standards and regulations

The regulators comply with the requirements of the European Pressure Equipment Directive 2014/68/EU. Devices with a CE marking have an EU declaration of conformity, which includes information about the applied conformity assessment procedure. This EU declaration of conformity is included in the Appendix of these instructions (see section 9.2).

Non-electric valve versions whose bodies are not lined with an insulating material coating do not have their own potential ignition source according to the risk assessment stipulated in EN 13463-1: 2009, section 5.2, even in the rare incident of an operating fault. Therefore, such valve versions do not fall within the scope of Directive 2014/34/EU.

→ For connection to the equipotential bonding system, observe the requirements specified in section 6.4 of EN 60079-14 (VDE 0165 Part 1).

Referenced documentation

The following documents apply in addition to these mounting and operating instructions:

- Mounting and operating instructions for the mounted actuator, e.g. ► EB 5857 for Type 5857 Actuator

1.1 Notes on possible severe personal injury

DANGER

Risk of bursting in pressure equipment.

Valves and pipelines are pressure equipment. Improper opening can lead to device components bursting.

- Before starting any work on the device, depressurize all plant sections concerned as well as the valve.
- Drain the process medium from all the plant sections concerned as well as the valve.
- If necessary, install a suitable overpressure protection in the plant section.
- Wear personal protective equipment.

1.2 Notes on possible personal injury

WARNING

Risk of personal injury due to residual process medium in the valve.

While working on the valve, residual process medium can escape and, depending on its properties, may lead to personal injury, e.g. (chemical) burns.

- If possible, drain the process medium from all the plant sections concerned and the valve.
- Wear protective clothing, safety gloves and eyewear.

Risk of burn injuries due to hot or cold components and pipelines.

Depending on the process medium, valve components and pipelines may get very hot or cold and cause burn injuries.

- Allow components and pipelines to cool down or heat up.
- Wear protective clothing and safety gloves.

1.3 Notes on possible property damage

NOTICE

Risk of valve damage due to contamination (e.g. solid particles) in the pipeline.

The plant operator is responsible for cleaning the pipelines in the plant.

- Flush the pipelines before start-up.
- Observe the maximum permissible pressure for valve and plant.

Risk of valve damage due to unsuitable medium properties.

The valve is designed for process media with defined properties.

- Only use process media specified for sizing the valve.

2 Markings on the device

2.1 Nameplate for Type 2488 N Valve

1	2
3	4
5	6
7	8
9	9

Nameplate for Type 2488 N Valve

- 1 Model number and configuration ID
- 2 Order number or year of manufacture
- 3 Type designation
- 4 Flow rate set point range in m³/h
- 5 Differential pressure at the restriction in bar
- 6 Max. perm. differential pressure Δp in bar
- 7 Flow coefficient K_{VS}
- 8 Max. permissible temperature in °C
- 9 Nominal pressure PN

Three-step version

SAMSON 5857
Electric Actuator

F: 3 s: 4 t: 5 U: 6 f: 7 P: 8

Var.-ID 1

Serial-No. 2 Made in Germany

SAMSON 5857
Electric Actuator
with digital positioner

F: 3 s: 4 ln: 9 U: 6 P: 8

Var.-ID 1 Firmware-Version: 10

Serial-No. 2 Made in Germany

Nameplate of Type 5857 Actuator

- 1 Configuration ID
- 2 Serial number
- 3 Thrust
- 4 Rated travel
- 5 Transit time for rated travel
- 6 Power supply
- 7 Rated frequency
- 8 Power consumption
- 9 Input signal
- 10 Firmware version

Fig. 1: Nameplates for Type 2488 N Valve and Type 5857 Actuator

3 Design and principle of operation

→ Refer to Fig. 2

The pressure-independent control valve (PICV) consists of the Type 2488 N Flow Regulator and the Type 5857 Electric Actuator. The valve is fitted with a connecting piece for connection of an electric actuator. As a result, it is possible to transmit the control signal of an electric control device to achieve additional temperature control by changing the restriction position. The medium flows through the valve in the direction indicated by the arrow on the valve body. The flow rate is determined by the area re-

leased by the valve plug (3) and the adjustable restriction (11).

The installed positioning spring (5) determines the differential pressure across the restriction of 0.2 bar. The pressure upstream of the restriction (11) is transmitted over the control line (7) to the upstream pressure side of the actuator. The pressure downstream of the restriction acts on the low-pressure side of the operating diaphragm (9) through a hole in the valve plug. The differential pressure generated at the restriction is converted into a positioning force by the operating diaphragm. This force is used to move the valve plug depending on the force of the positioning spring (5). The flow rate is adjusted at the set point screw (13).

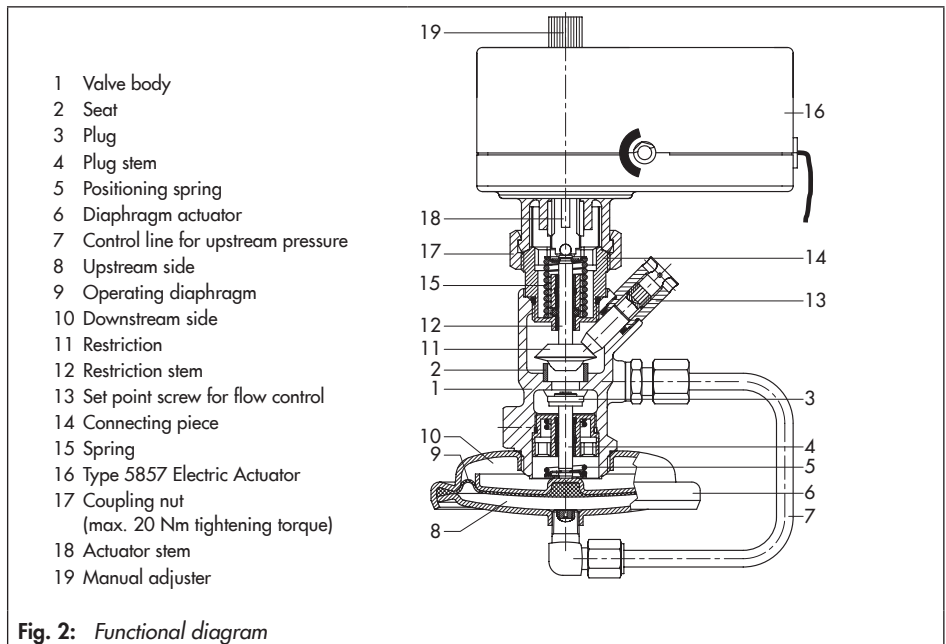

Fig. 2: Functional diagram

3.1 Technical data

The regulator's nameplate contains information on the regulator version (see section 2.1).

Process medium and scope of application

The **Type 2488 N/5857** Pressure-independent Control Valve (PICV) is suitable for the control of water and non-flammable gases.

- Non-flammable gases up to **80 °C**
- Liquids up to **110 °C**

The regulator is open when relieved of pressure. It closes when the downstream pressure rises above the adjusted set point.

Compliance

The Type 2488 N/5857 Regulator bears both the CE and EAC marks of conformity.



Temperature range

The Type 2488 N/5857 Regulator is designed for a temperature range from -10 to $+110$ °C (14 to 300 °F).

Leakage class

All regulators have the leakage class I according to IEC 60534-4.

Noise emission

SAMSON is unable to make general statements about noise emission as it depends on the valve version, plant facilities and process medium.

WARNING

Risk of hearing loss or deafness due to loud noise.

Wear hearing protection when working near the valve.

Dimensions and weights

Fig. 3 as well as Table 1 and Table 2 provide a summary of the dimensions and weights of the Type 2488 N/5857 Regulator. The lengths and heights in the dimensional drawings are shown on p. 13 onwards.

Table 1: *Technical data for Type 2488 N Valve*

Type 2488 N Valve		
Valve size	DN 15	
Nominal pressure	PN 10	
Max. perm. differential pressure Δp	4 bar	
K _{VS} coefficient	Standard version	2.5
	Special version	1.0
Max. permissible temperature	Treated water	110 °C
	Non-flammable gases	80 °C
Flow rate set point range/limitation for water with a differential pressure at the restriction of 0.2 bar	Standard version	0.3 to 1.0 m ³ /h
	Special version	0.1 to 0.5 m ³ /h
Differential pressure at the restriction	0.2 bar	
Materials		
Body	CC499K	
Plug	1.4301 with EPDM seal	
Restriction	Brass, free of dezincification	
Diaphragm	EPDM without fabric reinforcement	
Weight		
Valve	Approx. 1.0 kg	

Design and principle of operation

Table 2: Technical data of Type 5857 Actuator

Type 5857 Actuator	Version	Three-step	With digital positioner
Connection to valve		Force-locking	
Rated travel		6 mm	
Transit time for rated travel		20 s	30/20 ¹⁾ /10 s
Thrust		300 N	
Power supply		230 V (±10 %), 50 Hz 24 V (±10 %), 50 Hz	24 V (±10 %), 50 Hz, 60 Hz and DC ²⁾
Power consumption		Approx. 3 VA	5 VA
Manual override		Yes	
Permissible temperatures			
Ambient		0 to 50 °C	
Storage		-20 to +70 °C	
Medium		0 to 120 °C	
Degree of protection		IP 42 according to EN 60529	
Class of protection		II according to EN 61140	
Electromagnetic compatibility		According to EN 61000-6-2, EN 61000-6-3 and EN 61326	
Compliance		CE · EAC	
Digital positioner		-	
Input signal		0 to 10 V ¹⁾ , R _I = 20 kΩ	
Position feedback		0 to 10 V ¹⁾ , R _B = 1 kΩ	
Characteristic		- Linear ¹⁾ , equal percentage, reverse equal percentage, user- defined	
Materials			
Housing		Plastic (PPO)	
Coupling nut		Brass · M32x1.5 connection	
Intermediate insulating piece		1.4306, CW617N, PTFE, EPDM, FKM	
Weight			
Valve		Approx. 0.7 kg	

¹⁾ Default setting

²⁾ 10 s applies to 24 V DC (-0 %, +10 %) for Transit time for rated travel setting.

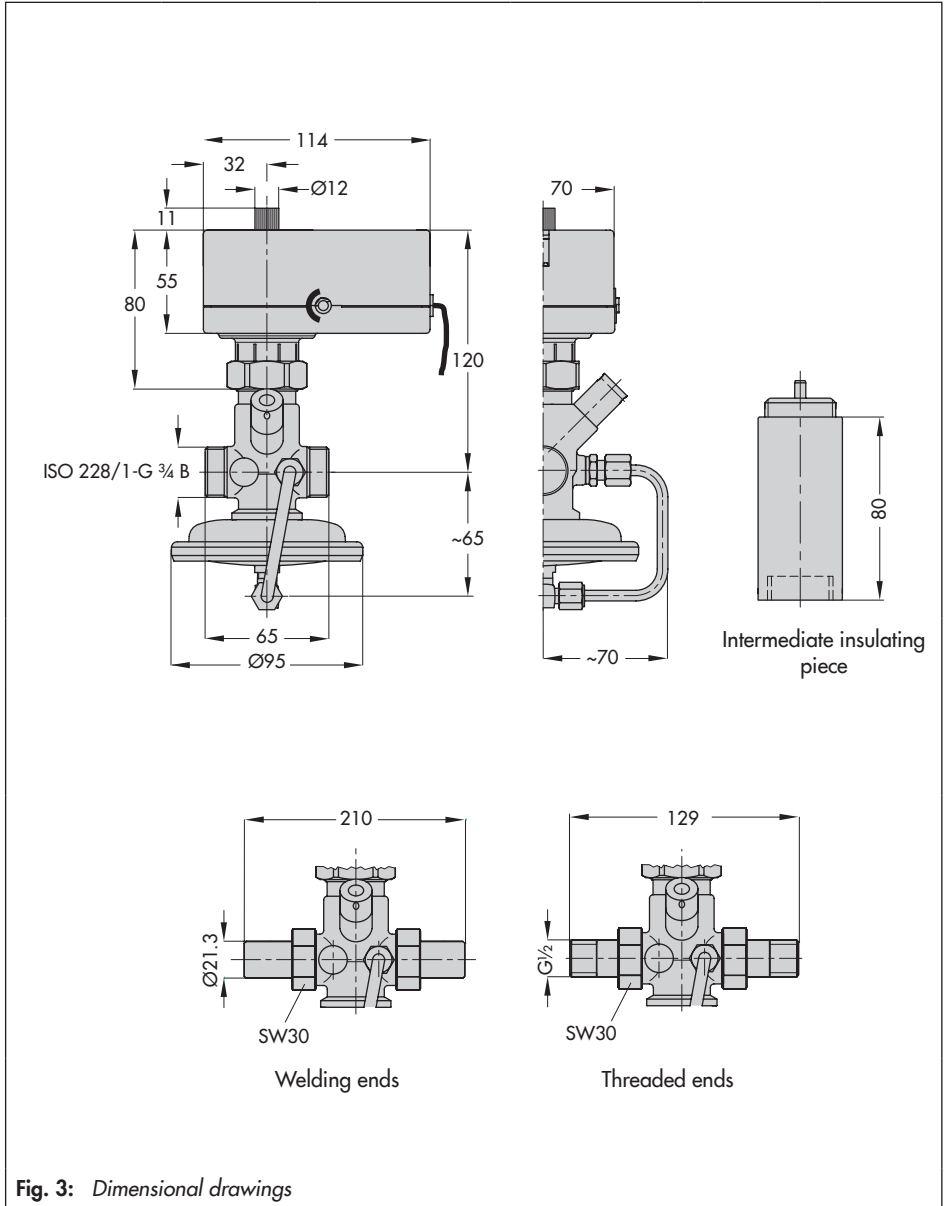

Fig. 3: Dimensional drawings

4 Measures for preparation

After receiving the shipment, proceed as follows:

1. Check the scope of delivery. Compare the shipment received with the delivery note.
2. Check the shipment for transportation damage. Report any damage to SAMSON and the forwarding agent (refer to delivery note).

4.1 Unpacking

i Note

Do not remove the packaging until immediately before installing the valve into the pipeline.

4.2 Transporting and lifting

Due to the low service weight, lifting equipment is not required to lift and transport the regulator (e.g. to install it into the pipeline).

Transport instructions

- Protect the device against external influences (e.g. impact).
- Do not damage the corrosion protection (paint, surface coatings). Repair any damage immediately.
- Protect the device against moisture and dirt.
- Observe the permissible ambient temperatures (see section 3.1).

4.3 Storage

! NOTICE

Risk of regulator damage due to improper storage.

- *Observe storage instructions.*
- *Avoid long storage times.*
- *Contact SAMSON in case of different storage conditions or long storage periods.*

i Note

We recommend regularly checking the device and the prevailing storage conditions during long storage periods.

Storage instructions

- Protect the device against external influences (e.g. impact).
- Do not damage the corrosion protection (paint, surface coatings). Repair any damage immediately.
- Protect the device against moisture and dirt. Store it at a relative humidity of less than 75 %. In damp spaces, prevent condensation. If necessary, use a drying agent or heating.
- Make sure that the ambient air is free of acids or other corrosive media.
- Observe the permissible ambient temperatures (see section 3.1).
- Do not place any objects on the device.

Special storage instructions for elastomers

Elastomer, e.g. actuator diaphragm

- To keep elastomers in shape and to prevent cracking, do not bend them or hang them up.
- We recommend a storage temperature of 15 °C for elastomers.
- Store elastomers away from lubricants, chemicals, solutions and fuels.

**Tip**

SAMSON's After-sales Service department can provide more detailed storage instructions on request.

4.4 Preparation for installation

Proceed as follows:

- Flush the pipelines.

i Note

The plant operator is responsible for cleaning the pipelines in the plant.

- Check the valve to make sure it is clean.
- Check the valve and actuator to make sure they are not damaged.
- Check to make sure that the type designation, valve size, material, pressure rating and temperature range of the valve and actuator match the plant conditions (size and pressure rating of the pipeline, medium temperature, etc.).
- Check any mounted pressure gauges to make sure they function.

5 Mounting and start-up

5.1 Mounting position

Standard mounting position

→ Install the regulator in a horizontal pipeline with the diaphragm actuator (δ) facing downward (see Fig. 2).

Installation conditions

- Make sure that the regulator remains freely accessible after the plant has been completed.
- The electric actuator must be mounted above the valve body.
- Install a strainer upstream of the regulator (see section 5.2).
- Make sure the direction of flow matches the direction indicated by the arrow on the body.
- Install the regulator free of stress.
- On insulating the valve, do not insulate the actuator and the coupling nut as well. If necessary, an intermediate insulating piece (order no. 1 690-6975) must be used. The insulating limit is in this case approx. 25 mm above the top of the valve body.

⚠ NOTICE

Possible malfunction and damage due to adverse weather conditions (temperature, humidity).

- Do not install the device outdoors or in rooms prone to frost.

- Protect the regulator against frost if it is used to control freezing media.
 - Either heat the regulator or remove it from the plant and completely drain the residual medium.
-

5.2 Additional fittings

Strainer

A strainer installed upstream in the flow pipe holds back any dirt or other foreign particles carried along by the medium. For example, the SAMSON Type 1 NI Strainer is suitable (▶ T 1010).

- Install the strainer upstream of the regulator.
- Make sure the direction of flow matches the direction indicated by the arrow on the body.
- Install the strainer with the filter element facing downward.
- Allow sufficient space to remove the filter.

Shut-off valve

Install a hand-operated shut-off valve both upstream of the strainer and at the outlet of the return flow pipe (see Fig. 4). This allows the plant to be shut down for cleaning and maintenance, and when the plant is not used for longer periods of time.

Pressure gauge

Install a pressure gauge at a suitable point to monitor the pressures prevailing in the plant (see Fig. 4).

5.3 Mounting the actuator

- Refer to Fig. 2
- Place the actuator (16) on the valve connection and hand-tighten the coupling nut (17).

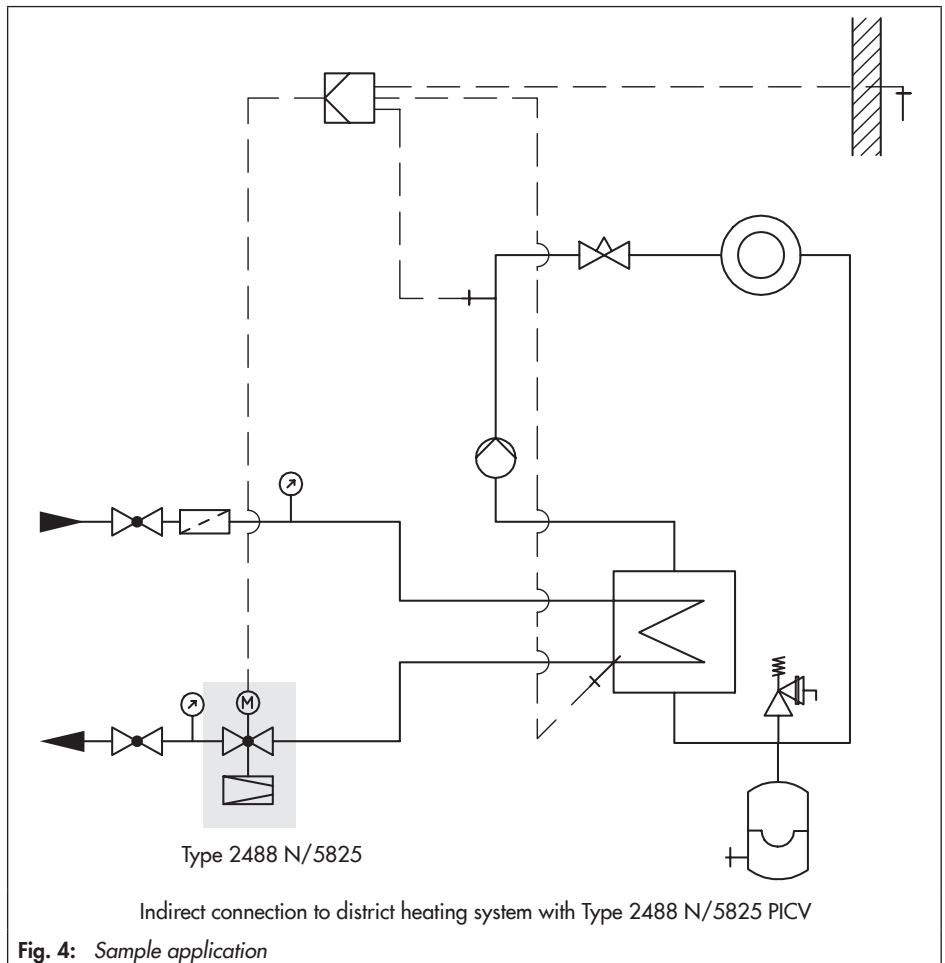

5.4 Electrical connection

→ See Fig. 5 and Fig. 2

⚠ WARNING

Upon installation of the electric cables, you are required to observe the regulations concerning power installations according to DIN VDE 0100 as well as the regulations of your local power supplier.

Use a suitable power supply which guarantees that no dangerous voltages reach the device in normal operation or in the event of a fault in the system or any other system parts.

Connect the actuator to the electrical network only after the power supply is first switched off. Make sure the power cannot be switched on unintentionally.

A power supply of 230 V (10 %) or 24 V (10 %), 50 Hz is required (▶ EB 5857 for more details).

→ Connect the electric actuator using the three-wire connecting cable (see Fig. 5).
If voltage is applied to the white and green wires, the actuator motor retracts the actuator stem (18). The restriction stem (12) is pushed upward by the spring (15), causing the flow rate to rise.

In contrast, a control signal applied to the white and brown wires causes the actuator stem to extend. The restriction stem (12) is pushed downward by the spring (15), causing a lower flow rate.

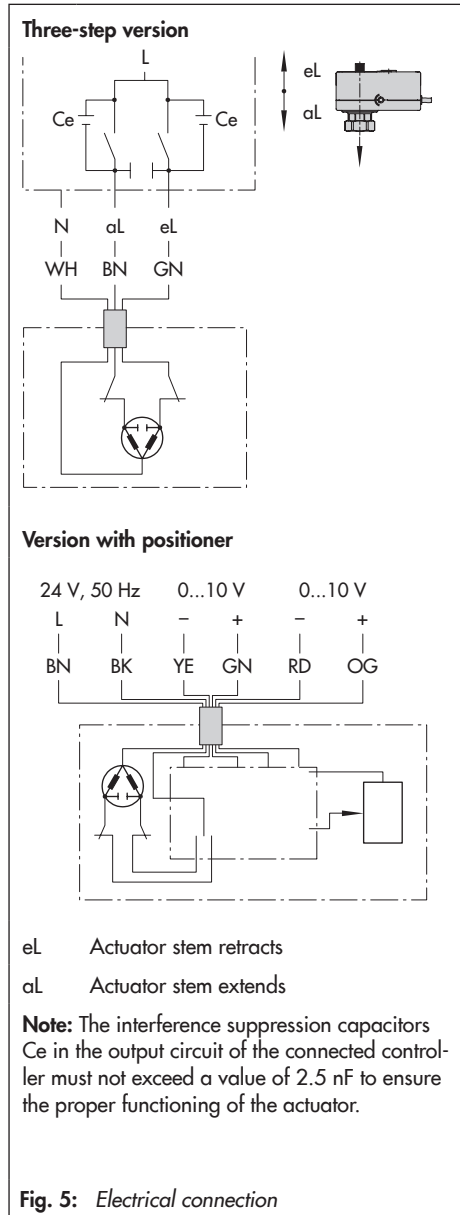

Fig. 5: Electrical connection

5.5 Start-up

- First start up the regulator after mounting all parts.
- Make sure that the restriction (11) is open while filling the plant. Remove the electric actuator and turn the set point screw for the flow control (13) counter-clockwise (↺) as far as it will go (see Fig. 2).
- Starting on the upstream side, open the shut-off valves slowly over a time period of several minutes. Afterwards, open all the valves downstream of the regulator.

! NOTICE

Risk of valve damage due to a sudden pressure increase and resulting high flow velocities.

Slowly open the shut-off valve in the pipeline during start-up.

Pressure testing the plant

All plant components must be designed for the test pressure. If necessary, remove the regulator from the pipeline or remove the control line (7) of the diaphragm actuator at the valve and seal the open connection with a blanking plug (see Table 3).

! NOTICE

Risk of damage to the diaphragm actuator due to impermissible excess pressure.

The test pressure must not exceed the nominal pressure at the actuator by 1.5 times on testing the pressure of the plant when the regulator is already installed.

Rinsing the plant

1. After filling the plant, first completely open the consumer
2. Adjust the maximum flow rate at the regulator (see section 6.1.1).
3. Rinse out the pipeline at full flow rate for several minutes.
4. Check the strainer (e.g. measure the pressure drop) and clean it, if necessary.

Table 3: *Accessories*

Accessories	Item no.
Blanking plug	8323-0030
Seal	8412-0771

6 Operation

6.1 Adjusting the set point

6.1.1 Flow rate

→ Completely open the control and shut-off valves or the bypass valve in the plant.

To adjust or change the flow rate set point, proceed as follows:

Always adjust the set point based on a closed restriction.

NOTICE

Risk of damage to the restriction stem through one-side loading while turning the set point screw clockwise.

First turn the handwheel of the electric actuator to completely close the restriction.

1. To close the restriction (11), de-energize the electric actuator (16).
2. Turn the manual adjuster (19) clockwise (⌚) as far as it will go to close the restriction.
3. Use a suitable tool (Allen key, SW 4) to turn the set point screw (13) clockwise (⌚) as far as it will go.
4. Refer to Fig. 6 to find out how many turns are required to set the flow rate.
5. Use a suitable tool (Allen key, SW 4) to turn the set point screw (13) by the required number of turns. Turn it counter-clockwise (⌚) to open the restriction. The flow rate rises.

6. Guide the wire through the lead-seal hole and lead-seal it to fix the adjusted flow rate.
7. Reconnect the power supply to the electric actuator (16).

Tip

For exact adjustment, verify adjusted value with a heat or flow meter.

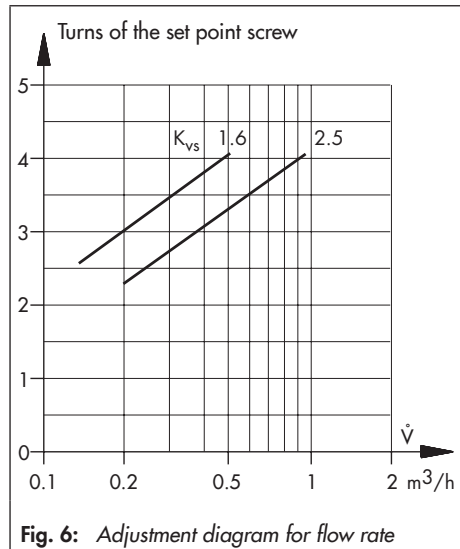

Fig. 6: Adjustment diagram for flow rate

7 Servicing

The regulator does not require any maintenance. Nevertheless, it is subject to natural wear, particularly at the seat, plug and operating diaphragm. Depending on the operating conditions, check the regulator at regular intervals to avoid possible malfunctions.



Tip

SAMSON's After-sales Service department can support you in drawing up an inspection and test plan for your plant.



DANGER

Risk of bursting in pressure equipment.

Valves and pipelines are pressure equipment. Improper opening can lead to device components bursting.

- Before starting any work on the device, depressurize all plant sections concerned as well as the valve.
- Drain the process medium from all the plant sections concerned as well as the valve.
- If necessary, install a suitable overpressure protection in the plant section.
- Wear personal protective equipment.



WARNING

Risk of personal injury due to residual process medium in the valve.

While working on the valve, residual process medium can escape and, depending on its properties, may lead to personal injury, e.g. (chemical) burns.

- If possible, drain the process medium from all the plant sections concerned and the valve.
- Wear protective clothing, safety gloves and eyewear.



WARNING

Risk of burn injuries due to hot or cold components and pipelines.

Depending on the process medium, valve components and pipelines may get very hot or cold and cause burn injuries.

- Allow components and pipelines to cool down or heat up.
- Wear protective clothing and safety gloves.



NOTICE

Risk of regulator damage due to incorrect servicing or repair.

Service and repair work must only be performed by trained staff.



NOTICE

Risk of regulator damage due to excessively high or low tightening torques.

Observe the specified torques on tightening regulator components. Excessively tightened torques lead to parts wearing out quicker. Parts that are too loose may cause leakage. Observe the tightening torques specified in Fig. 2.

i Note

The regulator was checked by SAMSON before it left the factory.

- The product warranty becomes void if service or repair work not described in these instructions is performed without prior agreement by SAMSON's After-sales Service.*
 - Only use original spare parts by SAMSON, which comply with the original specifications.*
-

7.1 Preparation for return shipment

Defective devices can be returned to SAMSON for repair. Proceed as follows to return devices to SAMSON:

1. Put the regulator out of operation (see section 8.1).
2. If necessary, decontaminate the regulator. Remove any residual process medium.
3. Fill in the Declaration on Contamination, which can be downloaded from our website at ► www.samsongroup.com > SERVICE & SUPPORT > After-sales Service > Returning goods.
4. Proceed as described on our website at ► www.samsongroup.com > SERVICE & SUPPORT > After-sales Service > Returning goods.

7.2 Ordering spare parts and operating supplies

Contact your nearest SAMSON subsidiary or the SAMSON After-sales Service for information on spare parts, lubricants and tools.

8 Malfunctions

The malfunctions listed in Table 4 are caused by mechanical faults and incorrect regulator sizing. In the simplest case, the functioning can be restored following the recommended action. Special tools may be required for repair work.

Exceptional operating and installation conditions may lead to changed situations that may affect the control response and lead to malfunctions. For troubleshooting, the conditions, such as installation, process medium, temperature and pressure conditions, must be taken into account.

SAMSON's After-sales Service can help during troubleshooting. Further information is available in section 9.1.

Table 4: Troubleshooting

Malfunction	Possible reasons	Recommended action
Flow rate exceeds adjusted set point	Leak between seat and plug	Remove valve from the pipeline and clean seat and plug. Contact SAMSON for further action.
	Defective operating diaphragm	Contact SAMSON's After-sales Service department.
	Control line with needle valve blocked.	Remove control line and needle valve. Clean them.
	Valve too large for control task (flow rate) or too small (differential pressure)	Recalculate K_{VS} and contact SAMSON for further action.
Flow set point not reached.	Leak between seat and plug	Remove valve from the pipeline and clean seat and plug. Contact SAMSON for further action.
	Incorrect set point range selected.	Check set point range and contact SAMSON for further action.
	Safety device, e.g. pressure limiter, has been triggered.	Check plant. Unlock safety device.
	Plant differential pressure too low.	Compare differential pressure in the plant with the plant's drag.
	Strainer blocked	Drain and clean filter of the strainer.
	Incorrectly installed valve (direction of flow).	Install the regulator so that the direction of flow matches the direction indicated by the arrow on the body.
Control loop hunts.	Valve too large for control task	Recalculate K_{VS} and contact SAMSON for further action.

i Note

Contact SAMSON's After-sales Service for malfunctions not listed in the table and when the malfunction cannot be remedied as described.

8.1 Decommissioning

To decommission the regulator for service and repair work or disassembly, proceed as follows:

1. Close the shut-off valve on the upstream side of the valve.
2. Close the shut-off valve on the downstream side of the valve.
3. Completely drain the pipelines and valve.
4. Depressurize the plant. Shut off or disconnect the control line.
5. If necessary, allow the pipeline and device to cool down or heat up.
6. Remove the valve from the pipeline.

8.2 Disposal

- Observe local, national and international refuse regulations.
- Do not dispose of components, lubricants and hazardous substances together with your household waste.

9 Appendix

9.1 After-sales service

Contact SAMSON's After-sales Service for support concerning service or repair work or when malfunctions or defects arise.

E-mail

You can reach our After-sales Service at aftersaleservice@samsongroup.com.

Addresses of SAMSON AG and its subsidiaries

The addresses of SAMSON AG, its subsidiaries, representatives and service facilities worldwide can be found on the SAMSON website

(▶ www.samsongroup.com) or in all SAMSON product catalogs.

To assist diagnosis and in case of an unclear mounting situation, specify the following details (so far as possible). See section 2:

- Device type and nominal size
- Model number and configuration ID
- Upstream and downstream pressure
- Temperature and process medium
- Min. and max. flow rate
- Is a strainer installed?
- Installation drawing showing the exact location of the regulator and all the additionally installed components (shut-off valves, pressure gauge, etc.)

9.2 Certificates

The EU declarations of conformity are included on the next pages.

SMART IN FLOW CONTROL



SAMSON

EU-KONFORMITÄTSERLÄRUNG EU DECLARATION OF CONFORMITY

Modul H/Module H, Nr./No. / N° CE-0062-PED-H-SAM 001-16-DEU-rev-A

SAMSON erklärt in alleiniger Verantwortung für folgende Produkte:/For the following products, SAMSON hereby declares under its sole responsibility:

Ventile für Druck- Differenzdruck-, Volumenstrom- und Temperaturregler/Valves for pressure, differential pressure, volume flow and temperature regulators

2333 (Erz.-Nr./Model No. 2333), 2334 (2334), 2335 (2335), 2336, 2373, 2375, 44-0B, 44-1B, 44-2, 44-3, 44-6B, 44-7, 44-8, 45-1, 45-2, 45-3, 45-4, 45-5, 45-6, 2468, 2478 (2720), 45-9, 46-5, 46-6, 46-7, 46-9, 47-1, 47-4, 47-5, 47-9, 2487, 2488, 2489, 2491, 2494, 2495 (2730), 2405, 2406, 2421 (2811), 2392, 2412 (2812), 2114 (2814), 2417 (2817), 2422 (2814), 2423 (2823)

die Konformität mit nachfolgender Anforderung/the conformity with the following requirement.

Richtlinie des Europäischen Parlaments und des Rates zur Harmonisierung der Rechtsvorschriften der Mitgliedstaaten über die Bereitstellung von Druckgeräten auf dem Markt. 2014/68/EU vom 15.05.2014

Directive of the European Parliament and of the Council on the harmonization of the laws of the Member States relating of the making available on the market of pressure equipment. 2014/68/EU of 15 May 2014

Angewandtes Konformitätsbewertungsverfahren für Fluide nach Art. 4(1)(c.i) und (c.i) zweiter Gedankenstrich. Modul siehe Tabelle durch certified by Bureau Veritas S. A. (0062)

Conformity assessment procedure applied for fluids according to Article 4(1)(c.ii) and (c.i), second indent See table for module

DN Pressure rating	15 NPS	20 ½	25 ¾	32 1	40 1¼	50 1½	65 2	80 -	100 3	125 4	150 -	200 6	250 8	300 10	400 12	400 16
PN 16	ohne/without (1)											A (2)(3)		H		
PN 25	ohne/without (1)											A (2)(3)		H		
PN 40	ohne/without (1)											A (2)(3)		H		
PN 100 und PN 160	ohne/without (1)											A (2)(3)		H		
Class 150	ohne/without (1)											A (2)(3)		H		
Class 300	ohne/without (1)											A (2)(3)		H		
Class 600 und Class 900	ohne/without (1)											H		-		

(1) Das auf dem Stellgerät aufgebrauchte CE-Zeichen hat keine Gültigkeit im Sinne der Druckgeräterichtlinie.

The CE marking affixed to the control valve is not valid in the sense of the Pressure Equipment Directive.

(2) Das auf dem Stellgerät aufgebrauchte CE-Zeichen gilt ohne Bezeichnung der benannten Stelle (Kenn-Nr. 0062).

The CE marking affixed to the control valve is valid without specifying the notified body (ID number 0062).

(3) Die Identifikationsnummer 0062 von Bureau Veritas S.A. gilt nicht für Modul A.

The identification number 0062 of Bureau Veritas S.A. is not valid for Modul A.

Geräte, denen laut Tabelle das Konformitätsbewertungsverfahren Modul H zugrunde liegt, beziehen sich auf die

„Zulassungsbescheinigung eines Qualitätssicherungssystems“ ausgestellt durch die benannte Stelle.

Devices whose conformity has been assessed based on Module H refer to the certificate of approval for the quality management system issued by the notified body.

Dem Entwurf zu Grunde gelegt sind Verfahren aus:/The design is based on the procedures specified in the following standards:

DIN EN 12516-2, DIN EN 12516-3 bzw./or ASME B16.1, ASME B16.24, ASME B16.34, ASME B16.42

Das Qualitätssicherungssystem des Herstellers wird von folgender benannter Stelle überwacht:

The manufacturer's quality management system is monitored by the following notified body:

**Bureau Veritas S.A. Nr./No. 0062, Newtime, 52 Boulevard du Parc, Ile de la Jatte, 92200 Neuilly sur Seine, France
Hersteller/Manufacturer: SAMSON AG, Weismüllerstraße 3, 60314 Frankfurt am Main, Germany**

Frankfurt am Main, 08. Februar 2017/08 February 2017

Klaus Hörschken
Zentralabteilungsleiter/Head of Central Department
Entwicklung Ventile und Antriebe/R&D, Valves and Actuators

Dr. Michael Heß
Zentralabteilungsleiter/Head of Central Department
Product Management & Technical Sales

SAMSON AKTIENGESELLSCHAFT
Weismüllerstraße 3 60314 Frankfurt am Main

Telefon: 069 4009-0 · Telefax: 069 4009-1507
E-Mail: samson@samson.de

Revision 03

SMART IN FLOW CONTROL



**EU-KONFORMITÄTSERKLÄRUNG
EU DECLARATION OF CONFORMITY**

Modul H/Module H, Nr./No. / N° CE-PED-H-SAM 001-13-DEU-rev-A

SAMSON erklärt in alleiniger Verantwortung für folgende Produkte:/For the following products, SAMSON hereby declares under its sole responsibility:

Ventile für Druck-, Differenzdruck-, Temperatur- und Volumenstromregler/Valves for pressure, temperature, flowregulators and differential pressure regulators

Typ 2336, 2373, 2375, 44-1B, 44-2, 44-3, 44-4, 44-6B, 44-9, 45-1, 45-2, 45-3, 45-4, 45-6, (Erz.-Nr. 2720), 45-9, 47-4, 2488, 2489, (2730), 2405, 2406, 2421 (2811), 2412 (2812), 2417 (2817), 2422 (2814), 2423 (2823), 2423E (2823)

die Konformität mit nachfolgender Anforderung/the conformity with the following requirement

Richtlinie des Europäischen Parlaments und des Rates zur Harmonisierung der Rechtsvorschriften der Mitgliedstaaten über die Bereitstellung von Druckgeräten auf dem Markt. 2014/68/EU vom 15.05.2014

Directive of the European Parliament and of the Council on the harmonization of the laws of the Member States relating of the making available on the market of pressure equipment (see also Articles 41 and 48). 2014/68/EU of 15 May 2014

Angewandtes Konformitätsbewertungsverfahren für Fluide nach Art. 4(1)(c.i) erster Gedankenstrich. Modult siehe Tabelle durch certified by Bureau Veritas S. A. (0062)
Conformity assessment procedure applied for fluids according to Article 4(1)(c.i), first indent See table for module

Nenndruck Pressure rating	DN NPS	15 ½	20 ¾	25 1	32 1¼	40 1½	50 2	65 -	80 3	100 4	125 -	150 6	200 8	250 10	300 12	400 16	
PN 16		ohne/without ⁽¹⁾				A ⁽²⁾⁽³⁾		-	-	-	-	-	-	-	-	-	-
PN 25		ohne/without ⁽¹⁾				A ⁽²⁾⁽³⁾		-	-	-	H	-	-	-	-	-	-
PN 40		ohne/without ⁽¹⁾						H									
PN 100 und PN 160		ohne/without ⁽¹⁾						H				-	-	-	-	-	-
Class 150		ohne/without ⁽¹⁾				A ⁽²⁾⁽³⁾				H							
Class 300		ohne/without ⁽¹⁾								H							
Class 600 und Class 900		ohne/without ⁽¹⁾						H				-	-	-	-	-	-

- (1) Das auf dem Stellgerät aufgebrauchte CE-Zeichen hat keine Gültigkeit im Sinne der Druckgeräterichtlinie. The CE marking affixed to the control valve is not valid in the sense of the Pressure Equipment Directive.
- (2) Das auf dem Stellgerät aufgebrauchte CE-Zeichen gilt ohne Bezeichnung der benannten Stelle (Kenn-Nr. 0062). The CE marking affixed to the control valve is valid without specifying the notified body (ID number 0062).
- (3) Die Identifikationsnummer 0062 von Bureau Veritas S.A. gilt nicht für Modul A. The identification number 0062 of Bureau Veritas S.A. is not valid for Modul A.

Geräte, denen laut Tabelle das Konformitätsbewertungsverfahren Modul H zugrunde liegt, beziehen sich auf die „Zulassungsbescheinigung eines Qualitätssicherungssystems“ ausgestellt durch die benannte Stelle.
Devices whose conformity has been assessed based on Module H refer to the certificate of approval for the quality management system issued by the notified body.

Dem Entwurf zu Grunde gelegt sind Verfahren aus:/The design is based on the methods of:
DIN EN 12516-2, DIN EN 12516-3 bzw./or ASME B16.1, ASME B16.24, ASME B16.34, ASME B16.42
Das Qualitätssicherungssystem des Herstellers wird von folgender benannter Stelle überwacht:
The manufacturer's quality management system is monitored by the following notified body:

**Bureau Veritas S.A. Nr./No. 0062, Newtime, 52 Boulevard du Parc, Ile de la Jatte, 92200 Neuilly sur Seine, France
Hersteller/Manufacturer: SAMSON AG, Weismüllerstraße 3, 60314 Frankfurt am Main, Germany**

Frankfurt am Main, 08. Februar 2017/08 February 2017

Klaus Hörschken
Klaus Hörschken
Zentralabteilungsleiter / Head of Central Department
Entwicklung Ventile und Antriebe / R&D, Valves and Actuators

Dr. Michael Heß
Dr. Michael Heß
Zentralabteilungsleiter / Head of Central Department
Product Management & Technical Sales

SAMSON AKTIENGESELLSCHAFT
Weismüllerstraße 3 60314 Frankfurt am Main

Telefon: 069 4009-0 · Telefax: 069 4009-1507
E-Mail: samson@samson.de

Revision 03

EU-Konformitätserklärung_Bilf_08_Modul_H_DE-EN_Rev03_2017-02-08.docx

EB 3136 EN



SAMSON AKTIENGESELLSCHAFT
Weismüllerstraße 3 · 60314 Frankfurt am Main, Germany
Phone: +49 69 4009-0 · Fax: +49 69 4009-1507
samson@samson.de · www.samson.de