

MOUNTING AND OPERATING INSTRUCTIONS



EB 6111 EN

Translation of original instructions



Type 6111 in standard version



Type 6111 mounted on a supply air manifold



Type 6111 in field enclosure

Type 6111 i/p Converter

Electropneumatic Converter for Direct Current Signals

Edition September 2017

CE Ex
certified

Note on these mounting and operating instructions

These mounting and operating instructions assist you in mounting and operating the device safely. The instructions are binding for handling SAMSON devices.

- For the safe and proper use of these instructions, read them carefully and keep them for later reference.
- If you have any questions about these instructions, contact SAMSON's After-sales Service (aftersalesservice@samsongroup.com).



The mounting and operating instructions for the devices are included in the scope of delivery. The latest documentation is available on our website at www.samsongroup.com > **Service & Support** > **Downloads** > **Documentation**.

Definition of signal words

DANGER

Hazardous situations which, if not avoided, will result in death or serious injury

WARNING

Hazardous situations which, if not avoided, could result in death or serious injury

NOTICE

Property damage message or malfunction

Note

Additional information

Tip

Recommended action

| | | |
|----------|--|-----------|
| 1 | Safety instructions and measures | 5 |
| 1.1 | Notes on possible severe personal injury | 7 |
| 1.2 | Notes on possible personal injury | 8 |
| 1.3 | Notes on possible property damage | 8 |
| 2 | Markings on the device | 9 |
| 2.1 | Nameplate | 9 |
| 2.2 | Article code | 10 |
| 3 | Design and principle of operation | 12 |
| 3.1 | Versions | 14 |
| 3.2 | Technical data | 16 |
| 3.3 | Accessories | 20 |
| 4 | Measures for preparation | 22 |
| 4.1 | Unpacking | 22 |
| 4.2 | Transporting and lifting | 22 |
| 4.3 | Storage | 22 |
| 4.4 | Preparation for installation | 22 |
| 5 | Mounting and start-up | 23 |
| 5.1 | Installing i/p converters | 23 |
| 5.1.1 | Installing the rail-mounting unit | 23 |
| 5.1.2 | Installing the field unit | 23 |
| 5.2 | Electrical connection | 23 |
| 5.3 | Pneumatic connection | 24 |
| 5.3.1 | Connecting the rail-mounting unit | 24 |
| 5.3.2 | Connecting the field unit | 24 |
| 5.4 | Mounting the supply air manifold for rail-mounting units | 24 |
| 5.4.1 | Fastening the supply air manifold | 25 |
| 5.4.2 | Assembling the supply air manifold | 25 |
| 5.4.3 | Connecting several supply air manifolds | 25 |
| 5.4.4 | Mounting the i/p converter on the manifold | 25 |

Contents

| | | |
|-----------|---|-----------|
| 6 | Operation | 29 |
| 6.1 | Checking zero and span | 29 |
| 6.1.1 | Checking zero | 29 |
| 6.1.2 | Checking span | 31 |
| 6.2 | Zero adjustment (versions with 0 to 20 mA input signal) | 31 |
| 7 | Servicing..... | 32 |
| 7.1 | Servicing explosion-protected devices | 32 |
| 8 | Malfunctions | 33 |
| 9 | Decommissioning and removal | 35 |
| 9.1 | Removing the i/p converters | 35 |
| 9.1.1 | Removint the rail-mounting unit | 35 |
| 9.2 | Removing the field unit | 35 |
| 9.3 | Disposal | 35 |
| 10 | Annex..... | 36 |
| 10.1 | After-sales service | 36 |
| 10.2 | Certificates | 36 |

1 Safety instructions and measures

Intended use

The Type 6111 i/p Converter is used to convert a direct current input signal into a pneumatic output signal for measuring and control tasks. The i/p converter is particularly suitable as an intermediate element between electric measuring devices and pneumatic controllers or between electric control devices and pneumatic control valves.

The device is designed to operate under exactly defined conditions (e.g. input signal, pressure). Therefore, operators must ensure that the device is only used in operating conditions that meet the specifications used for sizing the device at the ordering stage. In case operators intend to use the device in applications or conditions other than those specified, contact SAMSON.

SAMSON does not assume any liability for damage resulting from the failure to use the device for its intended purpose or for damage caused by external forces or any other external factors.

→ Refer to the technical data and nameplate for limits and fields of application as well as possible uses.

Reasonably foreseeable misuse

The device is not suitable for use outside the limits defined during configuration and by the technical data. Furthermore, the following activities do not comply with the intended use:

- Use of non-original spare parts
- Performing service and repair work not described

Qualifications of operating personnel

The device must be mounted, started up, serviced and repaired by fully trained and qualified personnel only; the accepted industry codes and practices must be observed. According to these mounting and operating instructions, trained personnel refers to individuals who are able to judge the work they are assigned to and recognize possible hazards due to their specialized training, their knowledge and experience as well as their knowledge of the applicable standards.

Safety instructions and measures

Personal protective equipment

We recommend checking the hazards posed by the plant and the process medium being used (e.g. ► GESTIS (CLP) hazardous substances database).

- Provide protective equipment (e.g. safety gloves, eye protection) appropriate for the material safety data sheet.
- Check with the plant operator for details on further protective equipment.

Revisions and other modifications

Revisions, conversions or other modifications of the product are not authorized by SAMSON. They are performed at the user's own risk and may lead to safety hazards, for example. Furthermore, the product may no longer meet the requirements for its intended use.

Warning against residual hazards

To avoid personal injury or property damage, operators and operating personnel must prevent hazards that could be caused in the device by the process medium and operating pressure by taking appropriate precautions. Plant operators and operating personnel must observe all hazard statements, warnings and caution notes in these mounting and operating instructions, especially for installation, start-up and service work.

Responsibilities of the operator

Operators are responsible for proper use and compliance with the safety regulations. Operators are obliged to provide these mounting and operating instructions as well as the referenced documents to the operating personnel and to instruct them in proper operation. Furthermore, operators must ensure that operating personnel or third parties are not exposed to any danger.

Responsibilities of operating personnel

Operating personnel must read and understand these mounting and operating instructions as well as the referenced documents and observe the specified hazard statements, warnings and caution notes. Furthermore, operating personnel must be familiar with the applicable health, safety and accident prevention regulations and comply with them.

Referenced standards, directives and regulations

Devices with a CE marking have an EU declaration of conformity, which includes information about the applied conformity assessment procedure. The EU declaration of conformity is included in the annex of these instructions (see section 10.2).

For electrical installation, observe the relevant electrotechnical regulations and the accident prevention regulations that apply in the country of use. In Germany, these are the VDE regulations and the accident prevention regulations of the employers' liability insurance.

For installation in hazardous areas, observe the relevant standards that apply in the country of use. Standard applicable in Germany: EN 60079-14 (VDE 0165, Part 1) Explosive Atmospheres – Electrical Installations Design, Selection and Erection.

The maximum permissible values specified in the EC type examination certificates apply when interconnecting intrinsically safe electrical equipment (U_i or U_o , I_i or I_o , P_i or P_o , C_i or C_o and L_i or L_o).

Referenced documentation

The following documents apply in addition to these mounting and operating instructions:

- Version as field unit: the mounting and operating instructions of the components on which the i/p converter is mounted (valve, actuator, valve accessories etc.)
- Safety Manual ► SH 6111 for use in safety-instrumented systems

1.1 Notes on possible severe personal injury

DANGER

Risk of fatal injury due to the formation of an explosive atmosphere.

Incorrect installation, operation or maintenance of the i/p converter in potentially explosive atmospheres may lead to ignition of the atmosphere and ultimately to death.

- ➔ The following regulations apply to installation in hazardous areas: EN 60079-14 (VDE 0165, Part 1).
- ➔ Installation, operation or maintenance of the i/p converter must only be performed by personnel who has undergone special training or instructions or who is authorized to work on explosion-protected devices in hazardous areas.

1.2 Notes on possible personal injury

WARNING

The i/p converter poses no hazard with possible personal injury.

- Check with the plant operator for details on possible personal injury which could be caused by the plant and ambient conditions (e.g. process medium, temperature).

1.3 Notes on possible property damage

NOTICE

A zero shift may occur due to shocks.

Shocks can cause a zero shift which impairs the correct functioning.

- Protect the device against external influences (e.g. impact, shocks).
- Check zero, if necessary (see section 6).

Risk of malfunction due to failure to comply with air quality requirements.

An insufficient air quality may lead to the output signal not being proportional to the input signal.

- Make sure that the air quality complies with the requirements (see section 3.2).
- Check the air filter and separator installed in the upstream air reducing station regularly.

2 Markings on the device

2.1 Nameplate

The nameplate shown was up to date at the time of publishing of this document. The nameplate on the device may differ from the one shown.

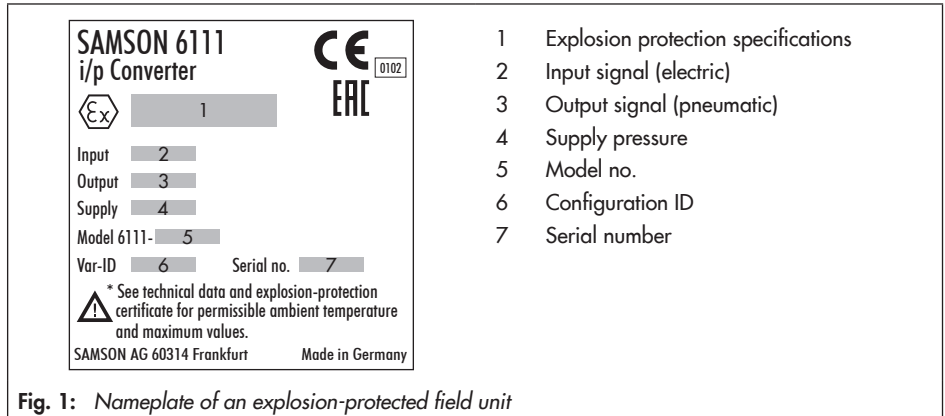

Fig. 1: Nameplate of an explosion-protected field unit

i Note

The Type 6109 and Type 6112 i/p Modules have their own nameplate which differs from the nameplate on the i/p converter.

Markings on the device

Location of the nameplate

The nameplate of the rail-mounting unit is lasered onto the front cover. The nameplate of the field unit is affixed to the field housing.

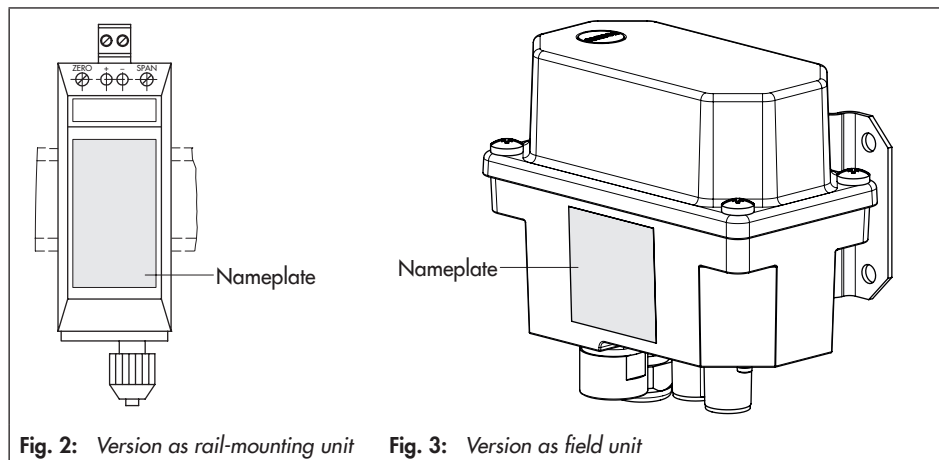

2.2 Article code

The article code is listed on the next page.

3 Design and principle of operation

The Type 6111 i/p Converter is used to convert a direct current input signal into a pneumatic output signal for measuring and control tasks. The i/p converter consists of an Type 6109 or Type 6112 i/p Converter Module and a downstream volume booster.

The i/p converter is available as a rail-mounting unit or field unit (see section 3.1).

The input is a load-independent direct current of 4 to 20 mA or 0 or 20 mA. The output is a pneumatic signal of 0.2 to 1 bar or other signal ranges up to max. 8 bar.

Principle of operation (see Fig. 6)

When operated, the supplied direct current i flows through the plunger coil (2) located in the field of a permanent magnet (3). At the

balance beam (1), the force of the plunger coil, which is in proportion to the current, is balanced against the force of the dynamic backpressure p_K , which is produced on the flapper (6) by the air jet leaving the nozzle (7). The supply air (SUPPLY 9) flows to the bottom chamber of the volume booster (8). A certain amount of air determined by the diaphragm position flows past the sleeve (8.5) and leaves through the output (OUTPUT 36).

The output signal p_A is used also to supply the nozzle (7). The offset spring (8.2) ensures that the output signal is at least 100 mbar even at an input signal of 0 mA. As the input current and the forces acting on the plunger coil increase, the flapper plate (6) moves closer to the nozzle (7). This causes the backpressure p_K upstream of the restriction (8.4) to rise. The cascade pressure increases until it corresponds with the input current.

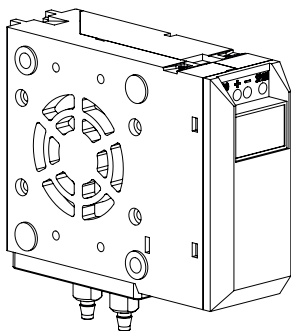

Fig. 4: Rail-mounting unit

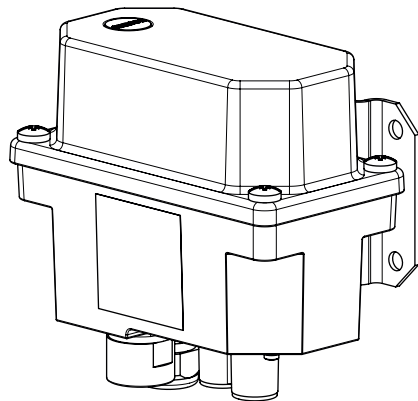

Fig. 5: Field unit with stainless steel housing

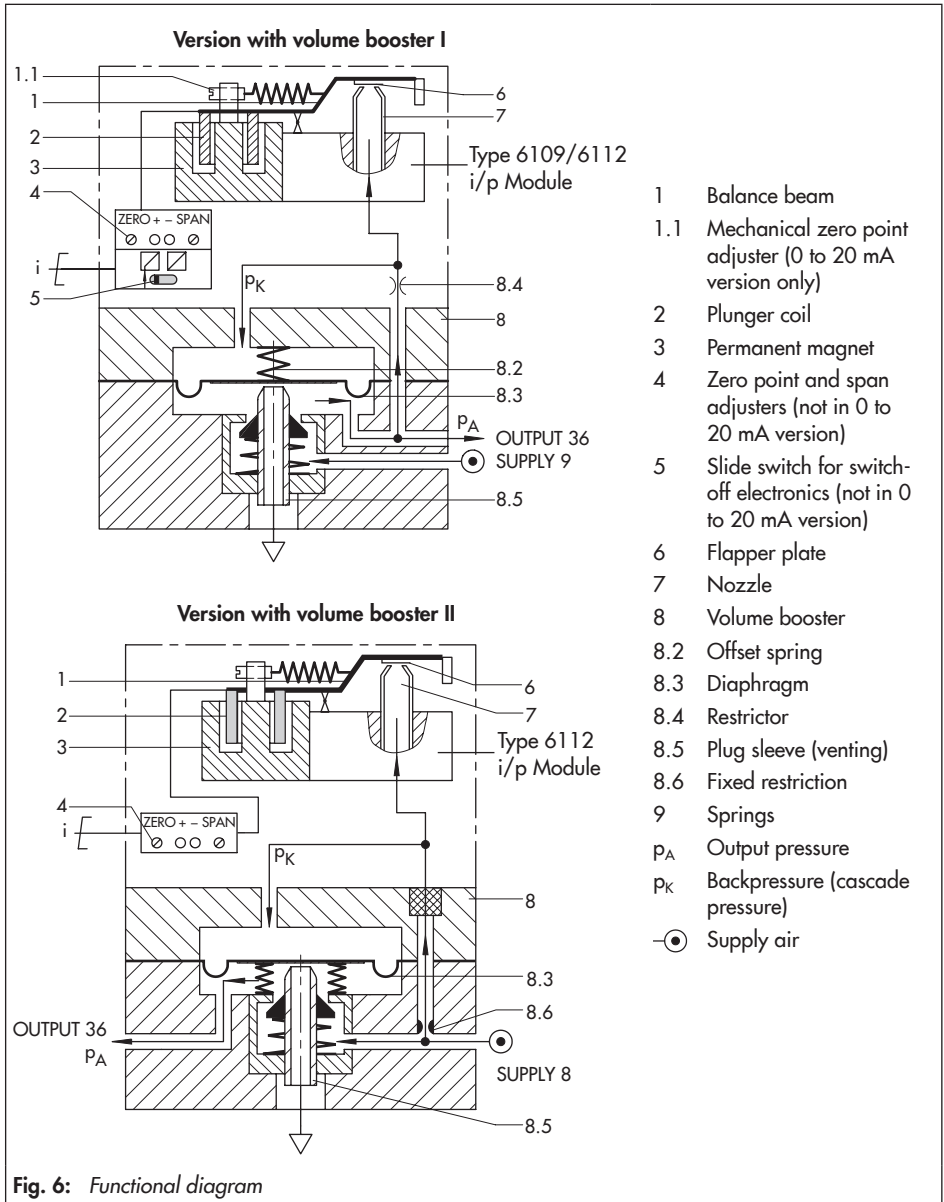

Fig. 6: Functional diagram

Design and principle of operation

The increasing backpressure pushes the diaphragm (8.3) and the plug sleeve (8.5) downwards. As a result, the supply air causes the output pressure p_A to increase until a new state of equilibrium is reached in the diaphragm chambers.

When the backpressure p_K drops, the diaphragm moves upwards, releasing the plug sleeve. The output pressure p_A can escape through the sleeve until the forces are equal again.

3.1 Versions

i Note

The nameplate and article code provide details on the device version (see section 2).

Rail-mounting unit

The i/p converter is designed for mounting on a top-hat rail.

Optionally, mount it to a wall using the two $\varnothing 5.5$ mm holes.

The devices can also be mounted to a supply air manifold using the corresponding accessories (see section 3.3 and section 5.4).

Field unit

The i/p converter is fitted with a field housing which allows it to be used directly in the field. The field unit is fastened using a mounting bracket which is included in scope of delivery (see section 3.3 for the order number).

Volume booster

The i/p converter is either fitted with the volume booster I or II (see Fig. 6 and Table 1).

A relatively stable supply air network is required for the version with volume booster II.

Switch-off electronics

Devices with an input range from 4 to 20 mA have a slide switch which activates the switch-off electronics (see Fig. 7). This function allows the input signal to be set to 0 mA when the signal falls below the switching point of 4.08 mA. This causes the pneumatic output to be vented to approximately 100 mbar. This guarantees, for example the tight shut-off function of a valve. This function requires a characteristic which passes through the zero point, for example at an output signal of 0.2 to 1 bar.



If the characteristic line does not pass through zero (e.g. for an allocated output signal from 0.8 to 2.7 bar), the pneumatic output is vented to a remaining pressure of approx. 0.3 bar when the switch-off electronics are activated.

Table 1: *Volume booster I and II*

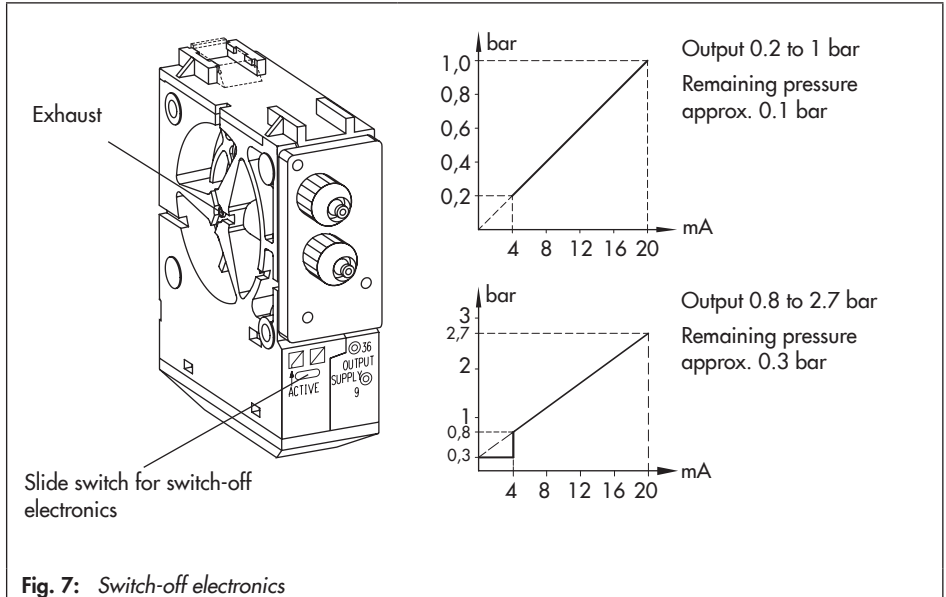
| Volume booster | I (Fig. 6 top) | II (Fig. 6 bottom) |
|----------------------|--|--|
| Output signal | 0.1 bar or higher | 0.0 bar or higher |
| i/p converter module | Type 6109 or Type 6112 | Type 6112 only |
| Sample application | It can be used in all applications allowing a zero point of min. 0.1 bar. Jumps in the supply air network can be compensated for, without affecting the output signal. For example, to control pneumatic control valves. | It can be used in applications requiring a zero point of 0 bar. For example, to control pneumatic cylinders or rollers used in the paper industry. |



3.2 Technical data

| Type 6111 | Rail-mounting unit | Field unit | |
|---|--|---|------------------|
| Explosion protection |  |  | |
| Input | 4 to 20 mA (0 to 20 mA on request) · For split-range: 4 to 12 mA or 12 to 20 mA · Other signals on request | | |
| Load Standard Explosion-protected version Without switch-off electronics | ≤ 6 V (corresponding to 300 Ω at 20 mA) 7 V (corresponding to 350 Ω at 20 mA) ≤ 4 V (corresponding to 200 Ω at 20 mA) | | |
| Standard range | 0.2 to 1 bar (3 to 15 psi) 0.4 to 2 bar (6 to 30 psi) | | |
| With Type 6112 i/p Module | Special ranges adjustable according to customer specifications | | |
| Out- put | Initial value ²⁾ | Span Δp | |
| | Module A | 0.1 to 0.4 bar | 0.75 to 1.0 bar |
| | Module B | 0.1 to 0.4 bar | 1.0 to 1.35 bar |
| | Module C | 0.1 to 0.4 bar | 1.35 to 1.81 bar |
| | Module D | 0.1 to 0.8 bar | 1.81 to 2.44 bar |
| | Module E | 0.1 to 0.8 bar | 2.44 to 3.28 bar |
| | Module F | 0.1 to 0.8 bar | 3.28 to 4.42 bar |
| | Module G | 0.1 to 1.2 bar | 4.42 to 5.94 bar |
| Module H | 0.1 to 1.2 bar | 5.94 to 8.0 bar ¹⁾ | |
| Max. air output capacity ³⁾ | 2.0 m ³ /h with an output of 0.6 bar (0.2 to 1.0 bar) 2.5 m ³ /h with an output of 1.2 bar (0.4 to 2.0 bar) 8.5 m ³ /h with an output of 5.0 bar (0.1 to 8.0 bar) | | |
| Supply air | At least 0.4 bar above the upper signal pressure range value Max. 10 bar without supply pressure regulator | | |
| Air quality acc. to ISO 8573-1: 2001 | Max. particle size and density: Class 4 · Oil content: Class 3 · Pressure dew point: Class 3 or at least 10 K below the lowest ambient temperature to be expected | | |
| Air consumption | 0.08 m _n ³ /h at 1.4 bar 0.1 m _n ³ /h at 2.4 bar Max. 0.26 m _n ³ /h at 10 bar | | |
| Characteristic | Characteristic: Output linear to input | | |

| Type 6111 | Rail-mounting unit | Field unit |
|---|--|---|
| Hysteresis | ≤0.3 % of final value | |
| Deviation from terminal-based conformity | ≤1 % of upper range value (for upper range values up to 5 bar); more exact values on request ≤1.5 % of upper range value (for upper range values above 5 bar) | |
| Effect in % of the upper range value | Supply air: 0.1 %/0.1 bar | |
| | Alternating load, supply air failure, interruption of the input current: <0.3 % | |
| | Ambient temperature: lower range value <0.03 %/K, span <0.03 %/K | |
| Dynamic response | At an output of 0.2 to 1 bar | |
| Limiting frequency | 5.3 Hz | |
| Phase shift | -130° | |
| Variable position | Max. 3.5 % depending on mounting position: e.g. ±1 % when mounted horizontally | |
| Ambient conditions, degree of protection | | |
| Storage temperature | -40 to +70 °C | |
| Ambient temperature | -20 to +70 °C | |
| Degree of protection | IP 20 | IP 65 |
| Materials | | |
| Housing | Glass-fiber-reinforced polyamide | Stainless steel 1.4581 Mounting bracket 1.4301 |
| Conformity | | |
|  | | |

- 1) The max. possible output pressure is 8 bar.
- 2) Initial value raised up to 3.0 bar (special version)
- 3) Measured with 2 m hose with 4 mm inside diameter

Dimensions and weights

The dimensions for the i/p converters are included on the next pages.

Dimensions in mm · Weights in kg

Table 2: Weights for Type 6111

| Type 6111 | Rail-mounting unit | Field unit |
|-----------------|--------------------|------------|
| Weight, approx. | 0.35 kg | 1.9 kg |

Design and principle of operation

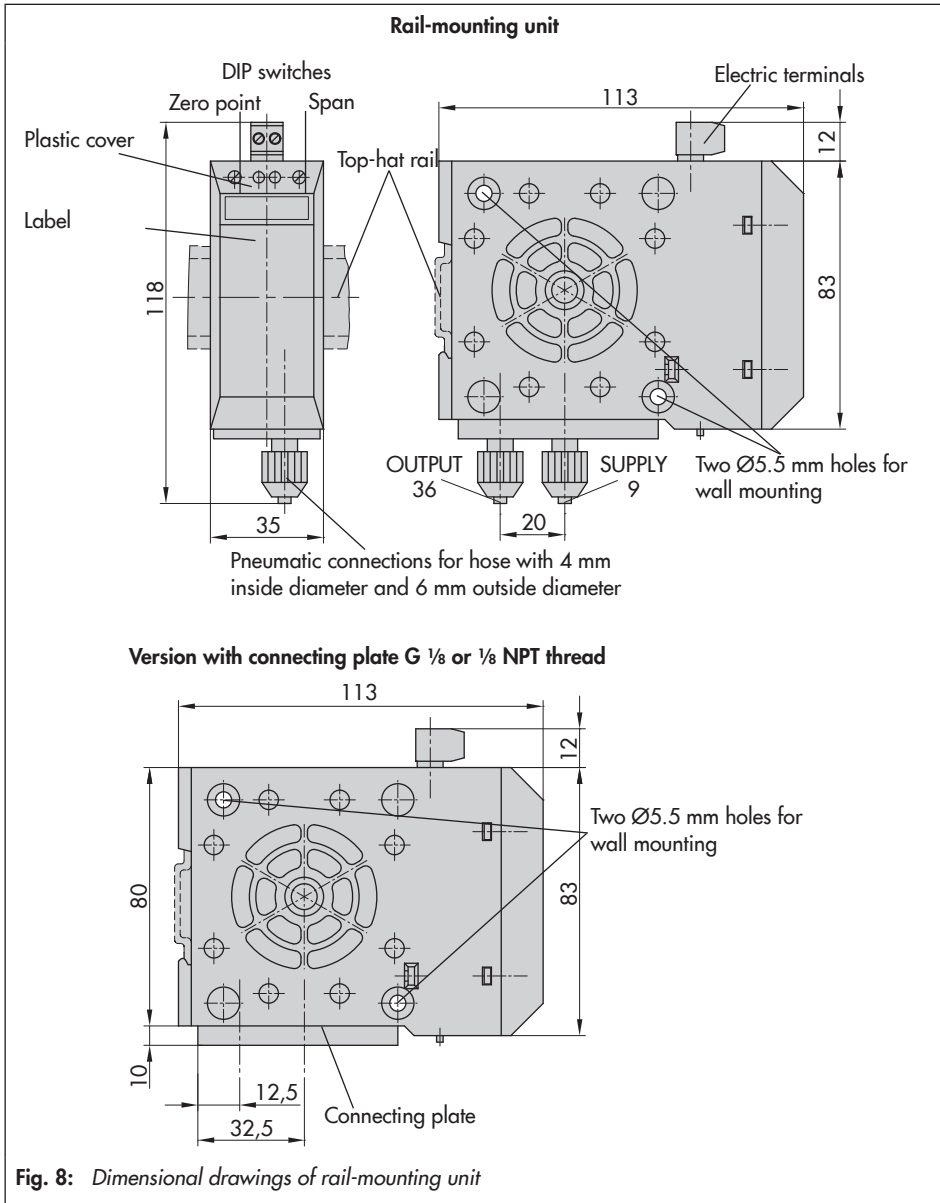

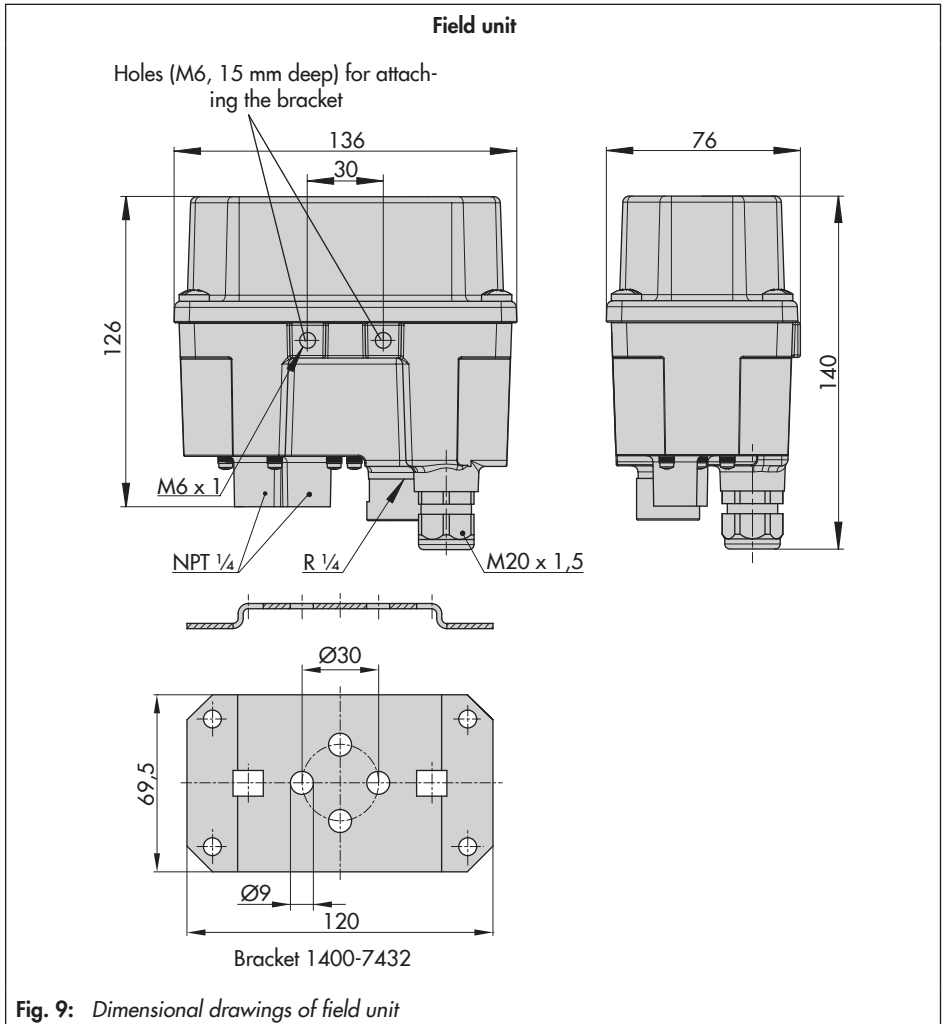

3.3 Accessories

The item numbers in parentheses (x) are listed in Fig. 11.

| Accessories/spare parts - Connecting plate or adapter plate | Order no. |
|---|-----------|
| Connecting plate with hose connection (without coupling nut) (15) | 0360-2950 |
| M10 x 1 coupling nut for hose connection (15) | 0250-1831 |
| Connecting plate 1/8 NPT (15) | 0360-3251 |
| Connecting plate G 1/8 (15) | 0360-3250 |
| Adapter plate for supply air manifold (16) | 0360-3096 |
| 3 x 12 mm screw for connecting plate with hose connection | 8336-0728 |
| 3 x 16 mm screw for connecting plate (NPT and G) | 8336-0730 |
| 3x10 mm screw for adapter plate for supply air manifold | 8336-0727 |
| Male screw fitting G 1/8 on hose with 4 mm inside diameter and 6 mm outside diameter, brass | 8582-1450 |
| Male screw fitting 1/4 NPT on hose, 4 mm inside diameter and 6 mm outside diameter, brass | 8582-1523 |
| Sintered filter for SUPPLY and OUTPUT connection | 0550-0653 |
| Seal for SUPPLY and OUTPUT connection | 0430-1134 |

| Accessories for field unit | Order no. |
|---|-----------|
| Mounting bracket (stainless steel) including two M6x12 hex head screws and washers to mount the field unit to the bracket Included in the scope of delivery. | 1400-7432 |

| Supply air manifold for converter units | 3 | 4 | 5 | 6 |
|---|-----------|------|------|------|
| | Order no. | | | |
| Supply air manifold (basic version) including two G 1/4 connectors | 1400-... | | | |
| With one screw plug | 7266 | 7273 | 7280 | 7287 |
| With pressure gauge (0 to 6 bar) | 7269 | 7276 | 7283 | 7290 |
| With pressure gauge (0 to 6 bar) and shut-off valve | 7270 | 7277 | 7284 | 7291 |
| Supply air manifold with hose push-on connections for outputs (hose with 4 mm inside diameter and 6 mm outside diameter) and supply air (hose with 8 mm inside diameter and 10 mm outside diameter) | 1400-... | | | |

| | | | | |
|--|------------------|------|------|------|
| With one screw plug | 7267 | 7274 | 7281 | 7288 |
| With pressure gauge (0 to 6 bar) and shut-off valve | 7271 | 7278 | 7285 | 7292 |
| Supply air manifold with hose screw fittings for outputs (hose with 4 mm inside diameter and 6 mm outside diameter) and supply air (hose with 8 mm inside diameter and 10 mm outside diameter) | 1400-... | | | |
| With one screw plug | 7268 | 7275 | 7282 | 7289 |
| With pressure gauge (0 to 6 bar) and shut-off valve | 7272 | 7279 | 7286 | 7293 |
| Coupling (5) to connect supply air manifolds including two NBR seals (4) | 1400-7294 | | | |

The item numbers in parentheses (x) are listed in Fig. 11.

| Accessories/spare parts · Supply air manifold | Thread | Connection for hose D/d | Length in mm, mounted | Order no. |
|---|--------|---|-----------------------|-----------|
| Pressure gauge, 0 to 6 bar (1) | G ¼ A | | 27 | 8520-0019 |
| Shut-off valve (11) | G ¼ | | 30 | 8502-0044 |
| Connector (3) | G ¼ | – | 20 | – |
| Connector G ¼ (3) | | | | 0230-2581 |
| Seal for connector (14x2.5 mm), NBR (4) | | | | 8421-0347 |
| Hose screw fitting, output (7a) | G ½ A | D/d = 6/4 | 19 | 8582-1450 |
| Hose push-on fitting, output (7b) | G ½ A | D/d = 6/4 | 13 | 8582-1563 |
| Washer (7.1) | | | | 8414-0136 |
| Hose screw fitting, supply air (10a) | G ¼ A | D/d = 10/8 | 21 | 8582-1735 |
| Seal (10.1), hose connection | | | | 8414-0140 |
| Hose push-on fitting, supply air (10b) | G ¼ A | D/d = 10/8 | 23 | 8582-1564 |
| Connecting plate, standard (15) | | D 6 hose, mounting onto supply air manifold | | 0360-2950 |
| Connecting plate, supply air manifold (16) | | | | 0360-3096 |
| Screw plug (2) | | | | 8323-0005 |
| M4x6 grub screw (6) | | | | 8324-0605 |
| M4x6 cap screw (8) | | | | 8333-0495 |
| 3 x 2.7 mm O-ring, NBR (9) | | | | 8421-0235 |

D = Outside diameter

d = Inside diameter

4 Measures for preparation

After receiving the shipment, proceed as follows:

1. Check the scope of delivery. Compare the shipment received with the delivery note.
2. Check the shipment for transportation damage. Report any damage to SAMSON and the forwarding agent (refer to delivery note).

4.1 Unpacking

- Do not remove the packaging until immediately before installation.
- Dispose of the packaging in accordance with the valid regulations.

4.2 Transporting and lifting

Transport instructions

- Protect the device against external influences (e.g. impact).
- Protect the device against moisture and dirt.
- Observe the permissible ambient temperatures (see section 3.2).

4.3 Storage

! NOTICE

Risk of device damage due to improper storage.

- *Observe the storage instructions.*
 - *Contact SAMSON in case of different storage conditions.*
-

Storage instructions

- Protect the device against external influences (e.g. impact).
- Protect the device against moisture and dirt. Store it at a relative humidity of less than 75 %. In damp spaces, prevent condensation. If necessary, use a drying agent or heating.
- Make sure that the ambient air is free of acids or other corrosive media.
- Observe the permissible ambient temperatures (see section 3.2).
- Do not place any objects on the device.

4.4 Preparation for installation

- Check the device for damage.
- Check the connections to make sure that they are clean.

5 Mounting and start-up

⚠ DANGER

Risk of fatal injury due to the formation of an explosive atmosphere.

Incorrect installation, operation or maintenance of the i/p converter in potentially explosive atmospheres may lead to ignition of the atmosphere and ultimately to death.

- The following regulations apply to installation in hazardous areas:
EN 60079-14 (VDE 0165, Part 1).
- Installation, operation or maintenance of the i/p converter must only be performed by personnel who has undergone special training or instructions or who is authorized to work on explosion-protected devices in hazardous areas.

5.1 Installing i/p converters

5.1.1 Installing the rail-mounting unit

- ➔ Snap the i/p converter onto the top-hat rail.

i Note

- Optionally, mount it to a wall using the two $\varnothing 5.5$ mm holes.
- The devices can also be mounted to a supply air manifold using the corresponding accessories (see section 3.3 and section 5.4).

5.1.2 Installing the field unit

1. Fasten the supplied mounting bracket (1400-7432) onto the i/p converter using the two screws in the required position.
2. Insert the four other screws through the side holes and fasten tight.

5.2 Electrical connection

⚠ WARNING

Incorrect connection at the terminals will render the explosion protection unsafe.

Observe the specifications in the explosion-protection certification.

- ➔ For electrical installation, observe the relevant electrotechnical regulations and the accident prevention regulations that apply in the country of use. In Germany, these are the VDE regulations and the accident prevention regulations of the employers' liability insurance.
- ➔ Connect the wires for the input signal to the (+) and (–) terminals. The terminals

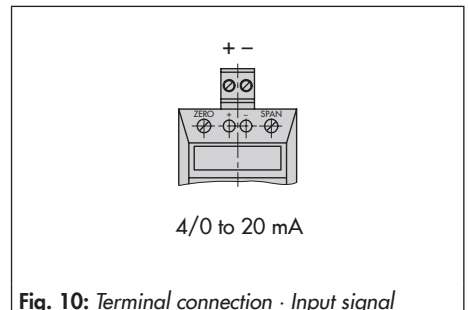

Fig. 10: Terminal connection · Input signal

Mounting and start-up

are designed for wires with 0.2 to 2.5 mm². No additional voltage supply is required.

Additional instructions for the electrical connection in hazardous areas

For installation in hazardous areas, observe the relevant standards that apply in the country of use. Standard applicable in Germany: EN 60079-14 (VDE 0165, Part 1) Explosive Atmospheres – Electrical Installations Design, Selection and Erection.

The maximum permissible values specified in the EC type examination certificates apply when interconnecting intrinsically safe electrical equipment (U_i or U₀, I_i or I₀, P_i or P₀, C_i or C₀ and L_i or L₀).

5.3 Pneumatic connection

The supply air must meet the following requirements:

- Min. + 0.4 bar above the upper signal pressure range
- Max. 10 bar

The air for the rail-mounting unit can optionally be supplied by the supply air manifold (see section 5.4).

5.3.1 Connecting the rail-mounting unit

The standard connections for supply air (SUPPLY 9) and output (OUTPUT 36) are designed as hose connections suitable for hose with 4 mm inside diameter and 6 mm outside diameter (see section 5.4). The hose

connections are also available with 1/8 NPT, G 1/8 or M5 female thread.

5.3.2 Connecting the field unit

The pneumatic connections (supply air and output) are designed as holes with 1/4-18 NPT thread.

5.4 Mounting the supply air manifold for rail-mounting units

The manifold (Fig. 11) is available as an accessory and provides a common air supply for several Type 6111 i/p Converters. The manifold can be made to be as long as required by combining two or more connecting rails of the manifolds for 3, 4, 5 and 6 converters. Individual connecting rails are connected by a coupling (5, order no. 1400-7294) with seals (4).

Optionally, the manifold can be fitted with a shut-off valve (11), pressure gauge (1) as well as hose connections (7; screw or push-on connections) for the output signals.

i Note

Supply air manifolds and the corresponding accessories are listed in section 3.3.

5.4.1 Fastening the supply air manifold

→ To fix the manifold to a wall or to a panel in a control cabinet, drill holes for M5 screws in the groove of the connecting rail. Make sure you keep 18 mm distance between the holes and the left and right edge of the rail to allow you to mount the i/p converters properly.

5.4.2 Assembling the supply air manifold

i Note

Connect the supply air either over the connector (3) or over a hose screw connection or push-on connection (10a or 10b).

1. Insert seals (4) on the connectors (3).
2. **Assembly without shut-off valve:** screw the hose screw connection (10a) or push-on connection (10b) with seal (10.1) into one of the two connectors (3) and tighten.

Assembly with shut-off valve: screw the shut-off valve (11) with seal (11.1) into the connector (3). Screw the hose screw connection (10a) or push-on connection (10b) with seal (10.1) into the shut-off valve.

3. **Assembly without pressure gauge:** screw screw plug (2) into the connector (3).

Assembly with pressure gauge: screw pressure gauge (1) into the connector (3).

4. Mount connectors at the ends of the manifold rail, align them and secure them in place with the grub screws (6).
5. **Assembly with hose screw connection:** screw fitting (7a) together with a washer (7.1) into the hole (G 1/8) on the bottom of the connecting rail.

Assembly with hose push-on connection: screw connection (7b) without an additional washer into the hole (G 1/8) on the bottom of the connecting rail.

5.4.3 Connecting several supply air manifolds

A coupling (5) with seals (4) is used to connect the individual connecting rails together:

1. Place seals (4) on the outer grooves of the coupling (5).
2. Press the coupling (5) into the manifold hole and push on the connecting rail as far as it will go.
3. Secure parts in place using grub screws (6).

5.4.4 Mounting the i/p converter on the manifold

1. Insert cap screws (8) from below into the holes in the connecting rail.
2. Push on O-rings (9) from the top to prevent the cap screws (8) from falling out.

Mounting and start-up

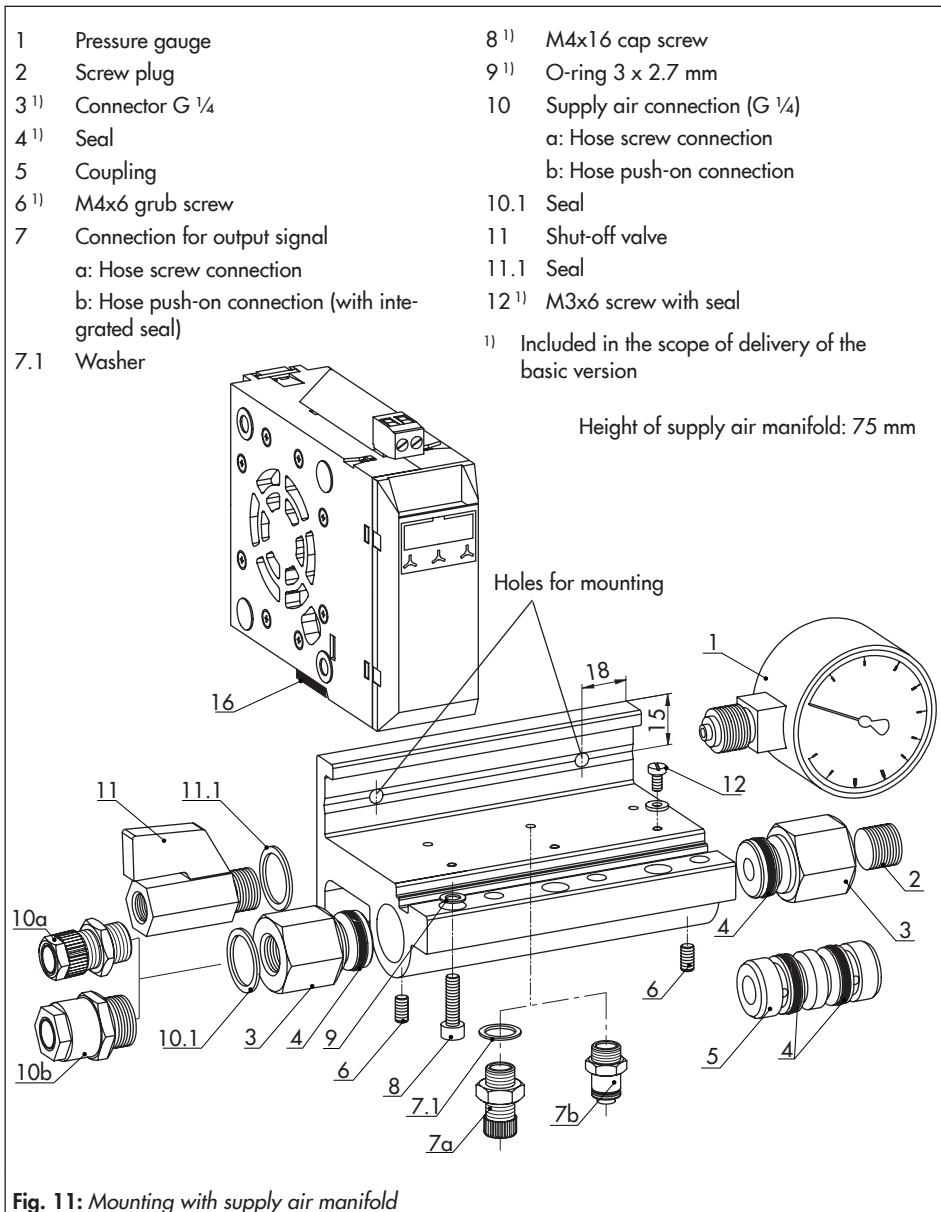
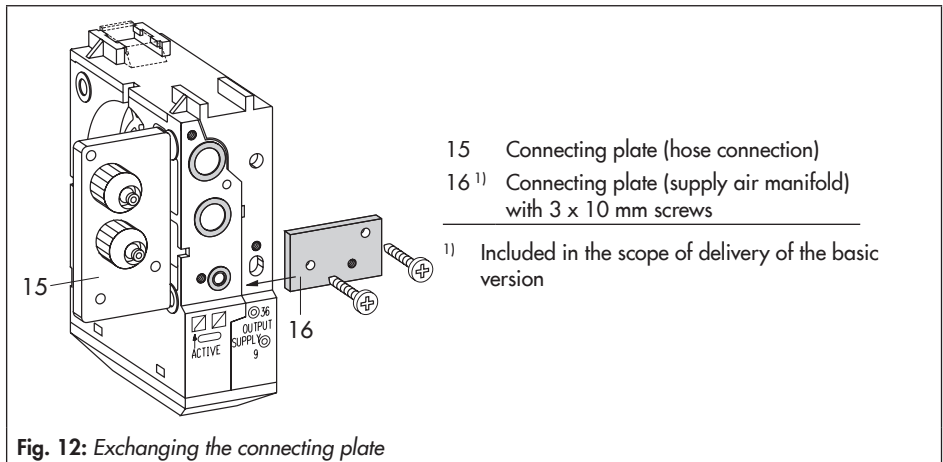

Fig. 11: Mounting with supply air manifold

3. Unscrew the original connecting plate (15) from the bottom of the i/p converter.
4. Fasten the black connecting plate (16) onto the i/p converter using the two 3x10 mm screws (Fig. 12).
5. Slightly tilt the i/p converter upwards and place it on the manifold. Press the converter down and secure it with the fastening screw (8).

i Note

If fewer Type 6111 Converters are mounted on the manifold than it is intended for, seal any unused holes in the supply air duct with the M3x6 cap screws (12) and seals included in the accessories.



Mounting and start-up

Table 3: Typical combination of connecting rails/supply air manifolds for 3 to 15 i/p converters

| Number of Type 6111 i/p Converter | Combination with coupling Units per manifold rail | | | | Manifold rail ¹⁾ Length [mm] Height: 75 mm |
|---|--|---|---|---|---|
| | 3 | 4 | 5 | 6 | |
| 3 | 1 | – | – | – | 108 |
| 4 | – | 1 | – | – | 144 |
| 5 | – | – | 1 | – | 180 |
| 6 | – | – | – | 1 | 216 |
| 7 | 1 | 1 | – | – | 252 |
| 8 | – | 2 | – | – | 288 |
| 9 | – | 1 | 1 | – | 324 |
| 10 | – | – | 2 | – | 360 |
| 11 | – | – | 1 | 1 | 369 |
| 12 | – | – | – | 2 | 432 |
| 13 | 1 | – | 2 | – | 468 |
| 14 | – | 1 | 2 | – | 504 |
| 15 | – | – | 3 | – | 540 |

¹⁾ Plus length of accessories

6 Operation

⚠ DANGER

Risk of fatal injury due to the formation of an explosive atmosphere.

Incorrect installation, operation or maintenance of the i/p converter in potentially explosive atmospheres may lead to ignition of the atmosphere and ultimately to death.

- *The following regulations apply to installation in hazardous areas: EN 60079-14 (VDE 0165, Part 1).*
- *Installation, operation or maintenance of the i/p converter must only be performed by personnel who has undergone special training or instructions or who is authorized to work on explosion-protected devices in hazardous areas.*

i Note

The versions with a 0 to 20 mA input signal do not have any switch-off electronics nor a potentiometer to adjust zero. If the device does not have a potentiometer for zero, the zero point can only be adjusted mechanically at the zero point adjuster (1.1). See section 6.2.

Some versions also do not have a potentiometer to adjust the span.

6.1 Checking zero and span

The device converts the input signal proportionally into the output signal.

The signal ranges are specified on the nameplate (see section 2.1). The specified range is fixed and can only be changed by approx. 10 % using the potentiometers.

If the device does not work properly for any reason, check the zero and span.

The **ZERO** and **SPAN** potentiometers are accessible through the holes in the front cover after opening the clear plastic cover (see Fig. 13).

i Note

The zero point of devices with volume booster I cannot be adjusted lower than 0.1 bar.

Do not adjust the characteristic in devices with volume booster II at all as the setting is much more complicated than in the version with volume booster I.

6.1.1 Checking zero

1. Connect a pressure gauge (minimum accuracy class 1) to the converter output.
2. Set the supply air to 0.4 bar above the upper output signal range value and apply it to the device.
3. Deactivate the switch-off electronics at the slide switch (5). Push the switch away from the ACTIVE arrow.
4. Set the input signal to the lower range value using a suitable ammeter.

Example: set it to 4 mA for 4 to 20 mA range = 0.2 to 1 bar. The output signal of the pressure gauge should now indicate 0.2 bar.

Operation

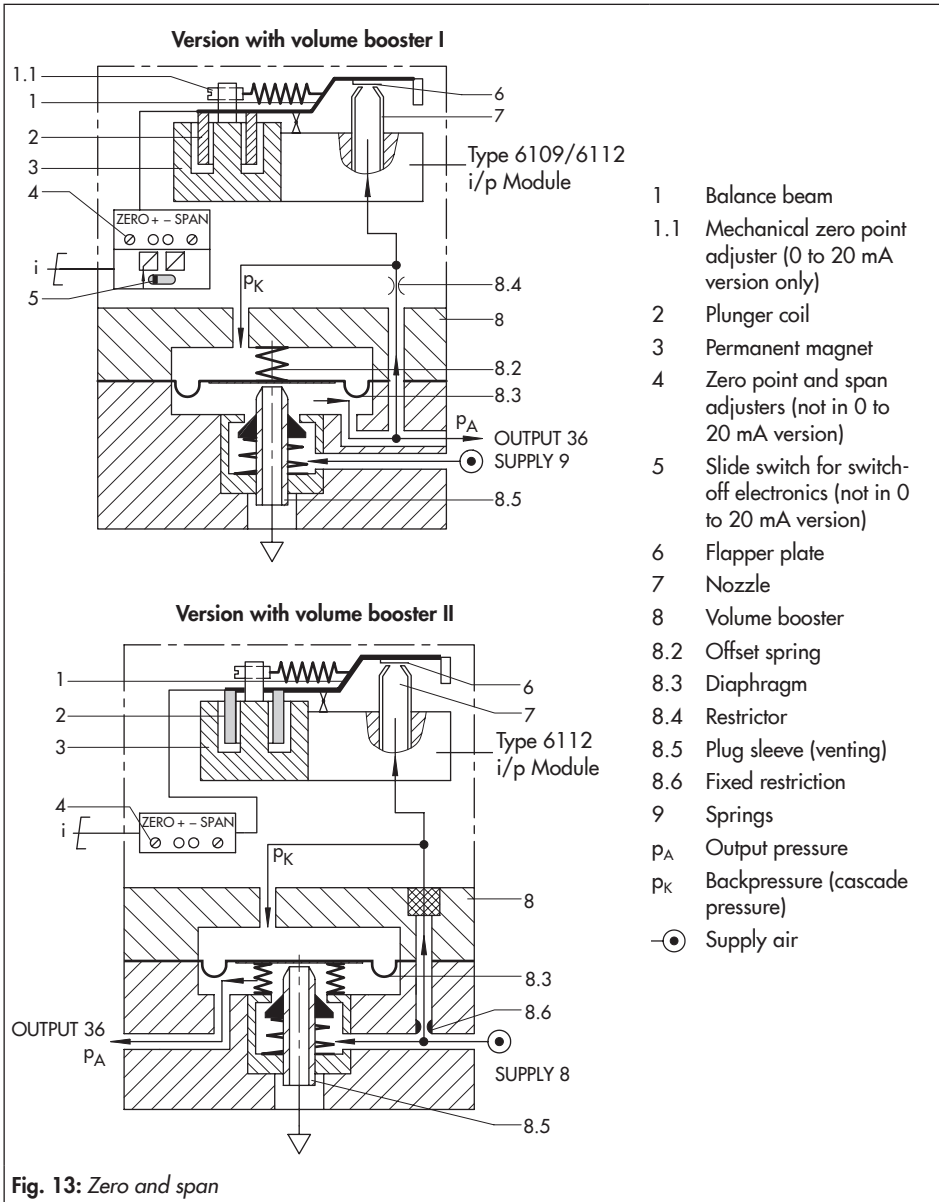

- 1 Balance beam
- 1.1 Mechanical zero point adjuster (0 to 20 mA version only)
- 2 Plunger coil
- 3 Permanent magnet
- 4 Zero point and span adjusters (not in 0 to 20 mA version)
- 5 Slide switch for switch-off electronics (not in 0 to 20 mA version)
- 6 Flapper plate
- 7 Nozzle
- 8 Volume booster
- 8.2 Offset spring
- 8.3 Diaphragm
- 8.4 Restrictor
- 8.5 Plug sleeve (venting)
- 8.6 Fixed restriction
- 9 Springs
- p_A Output pressure
- p_K Backpressure (cascade pressure)
- ⊙ Supply air

5. If this is not the case, readjust the zero point accordingly with the ZERO potentiometer.

6.1.2 Checking span

1. Set the input signal to 20 mA (upper range value) using a suitable ammeter.
Example: the output signal at the pressure gauge should now indicate 1.0 bar for a 4 to 20 mA range = 0.2 to 1.0 bar.
2. If this is not the case, readjust the span accordingly with the SPAN potentiometer.
3. As the adjustment of zero and span influence each other, recheck both values and correct them, if necessary.

6.2 Zero adjustment (versions with 0 to 20 mA input signal)

If the device does not have a potentiometer for zero, the zero point can only be adjusted mechanically at the zero point adjuster (1.1).

- Remove the front cover.
- Insert a screwdriver through the hole in the cover of the Type 6112 i/p Module (see Fig. 13).

7 Servicing

⚠ DANGER

Risk of fatal injury due to the formation of an explosive atmosphere.

Incorrect installation, operation or maintenance of the i/p converter in potentially explosive atmospheres may lead to ignition of the atmosphere and ultimately to death.

- The following regulations apply to installation in hazardous areas: EN 60079-14 (VDE 0165, Part 1).*
 - Installation, operation or maintenance of the i/p converter must only be performed by personnel who has undergone special training or instructions or who is authorized to work on explosion-protected devices in hazardous areas.*
-

The i/p converter requires no maintenance.

→ See section 8 for troubleshooting.

7.1 Servicing explosion-protected devices

If a part of the device on which the explosion protection is based needs to be serviced, the device must not be put back into operation until a qualified inspector has assessed it according to the requirements, has issued an inspection certificate or given the device a mark of conformity.

Inspection by a qualified inspector is not required if SAMSON performs a routine test on the device before putting it back into operation. Document the passing of the routine

test by attaching a mark of conformity to the device.

Replace explosion-protected components only with original, routine-tested components by the manufacturer.

Devices that have already been used outside hazardous areas and are intended for future use inside hazardous areas must comply with the safety requirements placed on serviced devices. Before being operated inside hazardous areas, test the devices according to the specifications for servicing explosion-protected devices.

8 Malfunctions

Depending on the operating conditions, check the valve at certain intervals to prevent a possible failure before it can occur. Plant operators are responsible for drawing up an inspection and test plan.



Tip

SAMSON's After-sales Service can support you in drawing up an inspection and test plan for your plant.

Table 4: Troubleshooting

| Malfunction | Possible reasons | Corrective action to be taken | Comments |
|---|---|---|--|
| No output signal despite changing the input signal | Supply air missing or not connected. | Check the supply air. See section 5.3. | – |
| | Incorrect terminal assignment | Connect + and – terminals correctly. See section 5.2. | NOTICE i/p converter does not need any extra voltage! Do not connect 24 V DC. |
| | Incorrect input signal | Connect correct signal. | Read nameplate: 0 to 20 mA or 4 to 20 mA. |
| Output signal does not change proportionally into the input signal. | Poor air quality. | Contact SAMSON's After-sales Service. | Make sure that the air quality complies with the requirements (see section 3.2). Check the air filter and separator installed in the upstream air reducing station regularly. |
| | Mechanics jammed (e.g. due to mechanical shock) | Contact SAMSON's After-sales Service. | – |
| | Sintered filter in SUPPLY and OUTPUT connection clogged up with dirt. | Clean or exchange sintered filter. | – |

Malfunctions

| Malfunction | Possible reasons | Corrective action to be taken | Comments |
|---|---|---|--|
| i/p converter constantly vents off air loudly | Connections for supply air and output at the i/p converter inadvertently reversed | Check pneumatic connections (see section 5.3). | – |
| i/p converter does not reach 100 % output e.g. 20 mA input: output only 70 % instead of 100 % | Supply pressure too low. | Supply air must be 0.4 bar higher than the max. output signal (supply air = 0.4 bar) | Read nameplate: output 0.2 to 1 bar → Supply air at least 1.4 bar |
| | Input signal faulty | Check whether the input signal at the terminals reaches 100 % (100 % is e.g. 20 mA in standard version and 12 mA for split-range operation) | NOTICE The i/p converters have a load of max. 6 V (standard version) or max. 7 V (Ex ia version). Check specification concerning permissible load at the source of the input signal. |
| | Consumption of air capacity too high. | Adapt consumption of the air capacity according to the technical data (see section 3.2). | – |

i Note

Contact SAMSON's After-sales Service for malfunctions not listed in the table.

9 Decommissioning and removal

⚠ DANGER

Risk of fatal injury due to the formation of an explosive atmosphere.

Incorrect installation, operation or maintenance of the i/p converter in potentially explosive atmospheres may lead to ignition of the atmosphere and ultimately to death.

- The following regulations apply to installation in hazardous areas: EN 60079-14 (VDE 0165, Part 1).
- Installation, operation or maintenance of the i/p converter must only be performed by personnel who has undergone special training or instructions or who is authorized to work on explosion-protected devices in hazardous areas.

9.1 Removing the i/p converters

9.1.1 Removint the rail-mounting unit

1. Disconnect the supply voltage and supply pressure.
2. Remove the pneumatic and electrical connections.
3. Remove the i/p converter from the top-hat rail.

9.2 Removing the field unit

1. Disconnect the supply voltage and supply pressure.
2. Remove the pneumatic and electrical connections.
3. Unscrew the four screws on the mounting bracket and remove the field unit.

9.3 Disposal

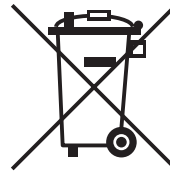

SAMSON is a producer registered at the following European institution ► <https://www.ewrn.org/national-registers/national-registers>.
WEEE reg. no.:
DE 62194439/FR 025665

- ➔ Observe local, national and international refuse regulations.
- ➔ Do not dispose of components, lubricants and hazardous substances together with your other household waste.

i Note

We can provide you with a recycling passport according to PAS 1049 on request. Simply e-mail us at aftersaleservice@samsongroup.com giving details of your company address.

💡 Tip

On request, we can appoint a service provider to dismantle and recycle the product as part of a distributor take-back scheme.

10 Annex

10.1 After-sales service

Contact SAMSON's After-sales Service for support when malfunctions or defects arise.

E-mail contact

You can reach our after-sales service at aftersalesservice@samsongroup.com.

Addresses of SAMSON AG and its subsidiaries

The addresses of SAMSON, its subsidiaries, representatives and service facilities worldwide can be found on our website (▶ www.samsongroup.com) or in all SAMSON product catalogs.

Required specifications

Please submit the following details:

- Order number and position number in the order
- Type and configuration ID
- Serial number
- Input and output ranges
- Installation drawing showing the exact location of the i/p converter

10.2 Certificates

The type examination certificate and the EU declaration of conformity are provided on the next pages.



TRANSLATION

(1) **EC TYPE EXAMINATION**

(2) Equipment and Protective
Atmospheres –

(3) EC Type Examination

(4) Equipment:

(5) Manufacture

(6) Address:

(7) The equipment
schedule to

(8) The Physika

Arrangements
equipment
requires
systems
to the Dir

The examin

(9) The essential

EN

(10) If the sign "X"
equipment is
to this certifi

(11) According
only to the
further req
equipment.



(12) The marking of the equipment shall include the following:

Zertifizierungsst
By order

(Signature)

Dr. Ing. U. J
Regierungsdi

(13)

(14) **EC TYPE EXAMINATION**

(15) **Description of Equipment**

The model 6111 is a
downstream pneumatic
current of 1 to 5 mA
of 0.2 to 1 bar d

The Model 6111
be connected to
maximum va

The correlati
temperature
below:

| Temperature |
|-------------|
| |
| |
| |
| |

Electrical d

Signal circuit
(terminals 11,

Maximum va

(16) Test report

(17) **Special conditions for safe use**

None

(18) **Special health and safety requirements**

In compliance with

Zertifizierungsstelle E
By order

(Signature)

Dr. Ing. U. Johann
Regierungsdirektor



T R A N S L A T I O N

- (1) **Statement of Conformity**
- (2) Equipment and Protective Systems Intended for Use in Potentially Explosive Atmospheres – **Directive 94/9/EC**
- (3) EC Type Examination Certificate Number

PTB 02 ATEX 2013 X

- (4) Equipment: Model 6111-8.. i/p-Converter
- (5) Manufacturer: SAMSON AG Mess- und Regeltechnik
- (6) Address: Weismüllerstr. 3, 60314 Frankfurt am Main, Germany
- (7) The equipment and any acceptable variation thereof are specified in the schedule to this certificate and the documents referred to therein.
- (8) The Physikalisch-Technische Bundesanstalt, notified body number 0102 according to Article 9 of the Council Directive 94/9/ of 23 March 1994, certifies that this equipment has been found to comply with the essential health and safety requirements relating to the design and construction of equipment and protective systems intended for use in potentially explosive atmospheres specified in Annex II to the Directive.

The examination and test results are recorded in confidential report.

PTB Ex 02-21420

- (9) The essential health and safety requirements are satisfied by compliance with
- EN 50021: 1999**
- (10) If the sign "X" is placed after the certificate number, it indicates that the equipment is subject to special conditions for safe use as specified in the schedule to this certificate.
- (11) In compliance with the Directive 94/9/EC this Statement of Conformity relates only to the design and construction of the equipment specified. Further requirements of this Directive apply to manufacture and marketing of this equipment.



(12) The marking of the equipment

Zertifizierungsstelle
By order

(Signature)

Dr. Ing. U. Johar
Regierungsdirke

(13)

S c h e d u l e

(14)

Statement of Conformity PTB 02 ATEX 2013 X

(15) **Description of Equipment**

The Model 6111-8
pneumatic convert
(0)4 to 20mA respe
respectively.

The device is inten

The correlation
temperature ra

| Temp |
|-------------|
| Temperature |

Electric

Signal circun
(terminals 11

(16) Test report: **PT**

(17) **Special conditi**

1. The Model 6
least Degree

The wiring sha
subjected to ter

(18) **Basic health ar**

Are satisfied

Zertifizierungsstelle
By order
(Signature)
Dr. Ing. U. Johan
Regierungsdirekt



EU Konformitätserklärung / EU Declaration of Conformity / Déclaration UE de conformité

Die alleinige Verantwortung für die Ausstellung dieser Konformitätserklärung trägt der Hersteller/
This declaration of conformity is issued under the sole responsibility of the manufacturer/
La présente déclaration de conformité est établie sous la seule responsabilité du fabricant.
Für das folgende Produkt / For the following product / Nous certifions que le produit

i/p-Umformer / i/p-Converter / Convertisseur i/p Typ/Type/Type 6111

wird die Konformität mit den einschlägigen Harmonisierungsrechtsvorschriften der Union bestätigt/
the conformity with the relevant Union harmonisation legislation is declared with/
est conforme à la législation d'harmonisation de l'Union applicable selon les normes:

EMC 2014/30/EU

EN 61000-6-2:2005, EN 61000-6-3:2007
+A1:2011, EN 61326-1:2013

RoHS 2011/65/EU

EN 50581:2012

Hersteller / Manufacturer / Fabricant:

SAMSON AKTIENGESELLSCHAFT
Weismüllerstraße 3
D-60314 Frankfurt am Main
Deutschland/Germany/Allemagne

Frankfurt / Francfort, 2017-07-29

Im Namen des Herstellers/ On behalf of the Manufacturer/ Au nom du fabricant.

Hanno Zager
Leiter Qualitätssicherung/Head of Quality Management/
Responsable de l'assurance de la qualité

Dirk Hoffmann
Zentralabteilungsleiter/Head of Department/Chef du département
Entwicklungsorganisation/Development Organization



EU Konformitätserklärung / EU Declaration of Conformity / Déclaration UE de conformité

Die alleinige Verantwortung für die Ausstellung dieser Konformitätserklärung trägt der Hersteller/
This declaration of conformity is issued under the sole responsibility of the manufacturer/
La présente déclaration de conformité est établie sous la seule responsabilité du fabricant.
Für das folgende Produkt / For the following product / Nous certifions que le produit

**i/p-Umformer / i/p-Converter / Convertisseur i/p
Typ/Type/Type 6111-1...**

entsprechend der EU-Baumusterprüfbescheinigung PTB 01 ATEX 2174 ausgestellt von der/
according to the EU Type Examination PTB 01 ATEX 2174 issued by/
établi selon le certificat CE d'essais sur échantillons PTB 01 ATEX 2174 émis par:

Physikalisch Technische Bundesanstalt
Bundesallee 100
D-38116 Braunschweig
Benannte Stelle/Notified Body/Organisme notifié 0102

wird die Konformität mit den einschlägigen Harmonisierungsrechtsvorschriften der Union bestätigt /
the conformity with the relevant Union harmonisation legislation is declared with /
est conforme à la législation d'harmonisation de l'Union applicable selon les normes:

| | |
|--|---|
| EMC 2014/30/EU | EN 61000-6-2:2005, EN 61000-6-3:2007 +A1:2011, EN 61326-1:2013 |
| Explosion Protection 94/9/EC (bis/to 2016-04-19) Explosion Protection 2014/34/EU (ab/from 2016-04-20) | EN 60079-0:2009, EN 60079-11:2012 |
| RoHS 2011/65/EU | EN 50581:2012 |

Hersteller / Manufacturer / Fabricant:

SAMSON AKTIENGESELLSCHAFT
Weismüllerstraße 3
D-60314 Frankfurt am Main
Deutschland/Germany/Allemagne

Frankfurt / Francfort, 2017-07-29

Im Namen des Herstellers/ On behalf of the Manufacturer/ Au nom du fabricant.

Hanno Zager
Leiter Qualitätssicherung/Head of Quality Management/
Responsable de l'assurance de la qualité

Dirk Hoffmann
Zentralabteilungsleiter/Head of Department/Chef du département
Entwicklungsorganisation/Development Organization

ce_6111-1_de_en_fr_mco7.pdf



EU Konformitätserklärung / EU Declaration of Conformity / Déclaration UE de conformité

Die alleinige Verantwortung für die Ausstellung dieser Konformitätserklärung trägt der Hersteller/
This declaration of conformity is issued under the sole responsibility of the manufacturer/
La présente déclaration de conformité est établie sous la seule responsabilité du fabricant.
Für das folgende Produkt / For the following product / Nous certifions que le produit

i/p-Umformer / i/p-Converter / Convertisseur i/p Typ/Type/Type 6111-8...

entsprechend der EU-Baumusterprüfbescheinigung PTB 02 ATEX 2013 X ausgestellt von der/
according to the EU Type Examination PTB 02 ATEX 2013 X issued by/
établi selon le certificat CE d'essais sur échantillons PTB 02 ATEX 2013 X émis par:

Physikalisch Technische Bundesanstalt
Bundesallee 100
D-38116 Braunschweig
Benannte Stelle/Notified Body/Organisme notifié 0102

wird die Konformität mit den einschlägigen Harmonisierungsrechtsvorschriften der Union bestätigt/
the conformity with the relevant Union harmonisation legislation is declared with/
est conforme à la législation d'harmonisation de l'Union applicable selon les normes:

| | |
|--|---|
| EMC 2014/30/EU | EN 61000-6-2:2005, EN 61000-6-3:2007 +A1:2011, EN 61326-1:2013 |
| Explosion Protection 94/9/EC (bis/to 2016-04-19) Explosion Protection 2014/34/EU (ab/from 2016-04-20) | EN 60079-0:2009, EN 60079-15:2010 |
| RoHS 2011/65/EU | EN 50581:2012 |

Hersteller / Manufacturer / Fabricant:

SAMSON AKTIENGESELLSCHAFT
Weismüllerstraße 3
D-60314 Frankfurt am Main
Deutschland/Germany/Allemagne

Frankfurt / Francfort, 2017-07-29

Im Namen des Herstellers/ On behalf of the Manufacturer/ Au nom du fabricant.

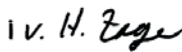

Hanno Zager
Leiter Qualitätssicherung/Head of Quality Management/
Responsable de l'assurance de la qualité

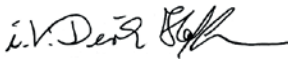

Dirk Hoffmann
Zentralabteilungsleiter/Head of Department/Chef du département
Entwicklungsorganisation/Development Organization

EB 6111 EN



SAMSON AKTIENGESELLSCHAFT
Weismüllerstraße 3 · 60314 Frankfurt am Main, Germany
Phone: +49 69 4009-0 · Fax: +49 69 4009-1507
samson@samsongroup.com · www.samsongroup.com